

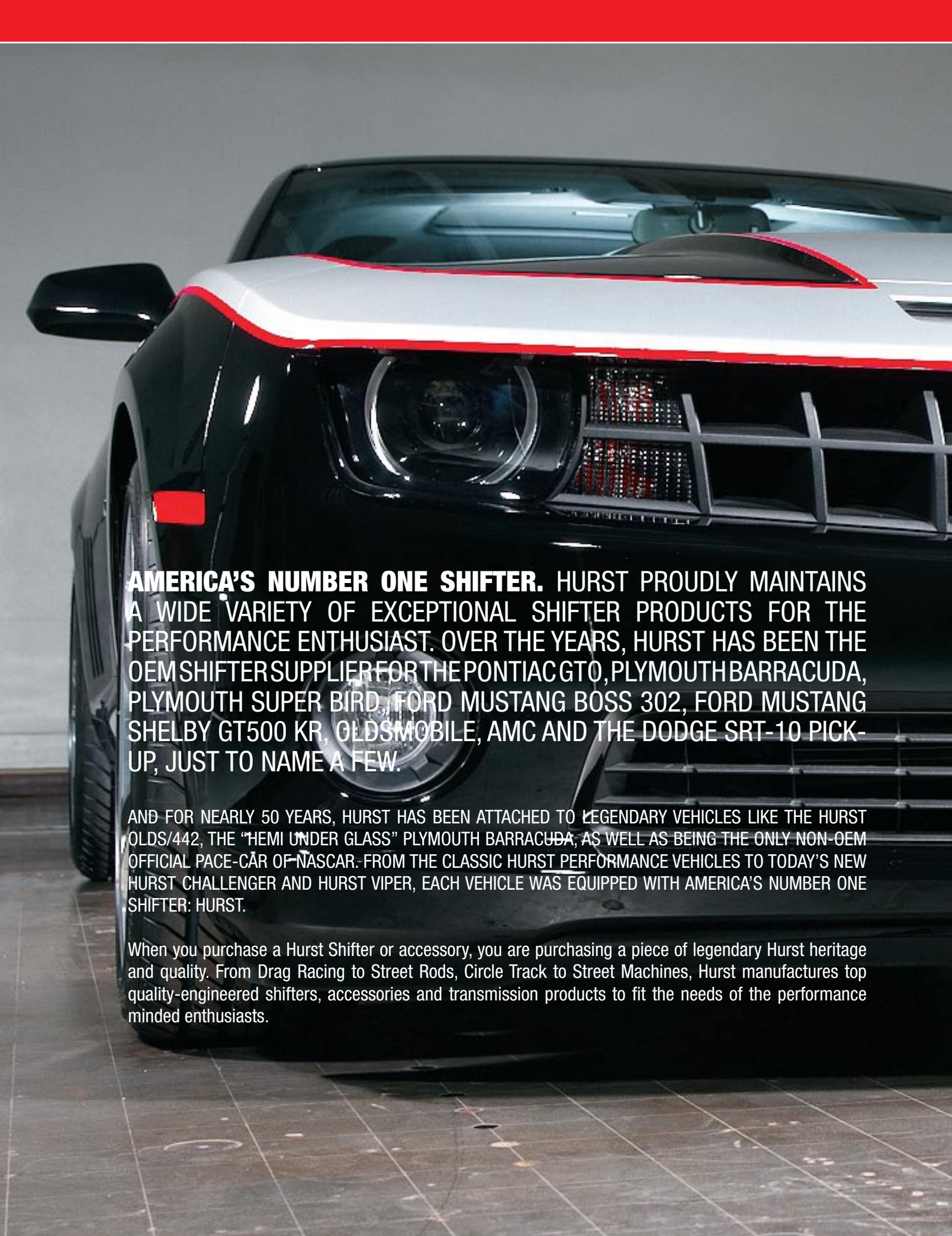

Hurst. America's Number One Shifter

PRODUCT CATALOG



A close-up, front-quarter view of a black sports car. The car features a white roof with a red stripe running along the edge. The front grille is prominent, with a circular headlight on the left and a rectangular grille section on the right. The car is parked on a dark, reflective floor.

AMERICA'S NUMBER ONE SHIFTER. HURST PROUDLY MAINTAINS A WIDE VARIETY OF EXCEPTIONAL SHIFTER PRODUCTS FOR THE PERFORMANCE ENTHUSIAST. OVER THE YEARS, HURST HAS BEEN THE OEM SHIFTER SUPPLIER FOR THE PONTIAC GTO, PLYMOUTH BARRACUDA, PLYMOUTH SUPER BIRD, FORD MUSTANG BOSS 302, FORD MUSTANG SHELBY GT500 KR, OLDSMOBILE, AMC AND THE DODGE SRT-10 PICK-UP, JUST TO NAME A FEW.

AND FOR NEARLY 50 YEARS, HURST HAS BEEN ATTACHED TO LEGENDARY VEHICLES LIKE THE HURST OLDS/442, THE "HEMI UNDER GLASS" PLYMOUTH BARRACUDA, AS WELL AS BEING THE ONLY NON-OEM OFFICIAL PACE-CAR OF NASCAR. FROM THE CLASSIC HURST PERFORMANCE VEHICLES TO TODAY'S NEW HURST CHALLENGER AND HURST VIPER, EACH VEHICLE WAS EQUIPPED WITH AMERICA'S NUMBER ONE SHIFTER: HURST.

When you purchase a Hurst Shifter or accessory, you are purchasing a piece of legendary Hurst heritage and quality. From Drag Racing to Street Rods, Circle Track to Street Machines, Hurst manufactures top quality-engineered shifters, accessories and transmission products to fit the needs of the performance minded enthusiasts.



TABLE OF CONTENTS

MANUAL SHIFTERS	2	AUTOMATIC SHIFTERS	13	SERVICE PARTS	31
Billet/Plus Shifters	3	Pro-Matic 2	14	SERVICE PARTS : APPLICATIONS	32
Competition/Plus Shifters.....	4	V-Matic 2	15	Competition/Plus, 4 Speed Installation Kits	32
Truck Shifters	5	The Original Quarter Stick	16	Quarter Stick, Automatic Shifter - Cable Operated	32
SHIFTER APPLICATIONS	6	Pistol-Grip Quarter Stick	17	Pro-Matic 2 & V-Matic 2, Automatic Shifter -	
Buick	6	Quarter Stick Accessories	18	Cable Operated	33
Chevrolet	6-7	Paddle-shift Kits	19	Replacement Shifter Springs	33
Chrysler	7	Comp Stick Kits	20-21	Mastershift, 3-Speed Installation Kits.....	33
Dodge.....	7	THE ORIGINAL ROLL/CONTROL	22	TRANSMISSION I.D. CHARTS	34
Ford	7	Roll/Control Accessories	23	3-Speed Transmission I.D. Chart	34
Jeep	8	SHIFTER ACCESSORIES	24	4-Speed Transmission I.D. Chart	34-35
Mercury	8	Shifter Knobs.....	24	5 And 6-Speed Transmission I.D. Chart	35
Oldsmobile	8	Pistol-Grip Handle	25	SHIFTER STICKS	36
Plymouth.....	8	T-Handles	26	HURST WARRANTY INFORMATION	37
Pontiac	8	HardDrive Sticks	27	SHIFTER REBUILD SERVICE	37
Shelby Mustang	8	Boots and Plates	28		
Studebaker.....	8	MISCELLANEOUS ACCESSORIES	29		
Street Super/Shifter 4-speed	9	Hurst Performance Wheels.....	29		
Mastershift 3-speed	10	PROMOTIONAL & LIFESTYLE ITEMS	30		
Indy Shifters	11				
Pro Billet Super/Speedway	12				

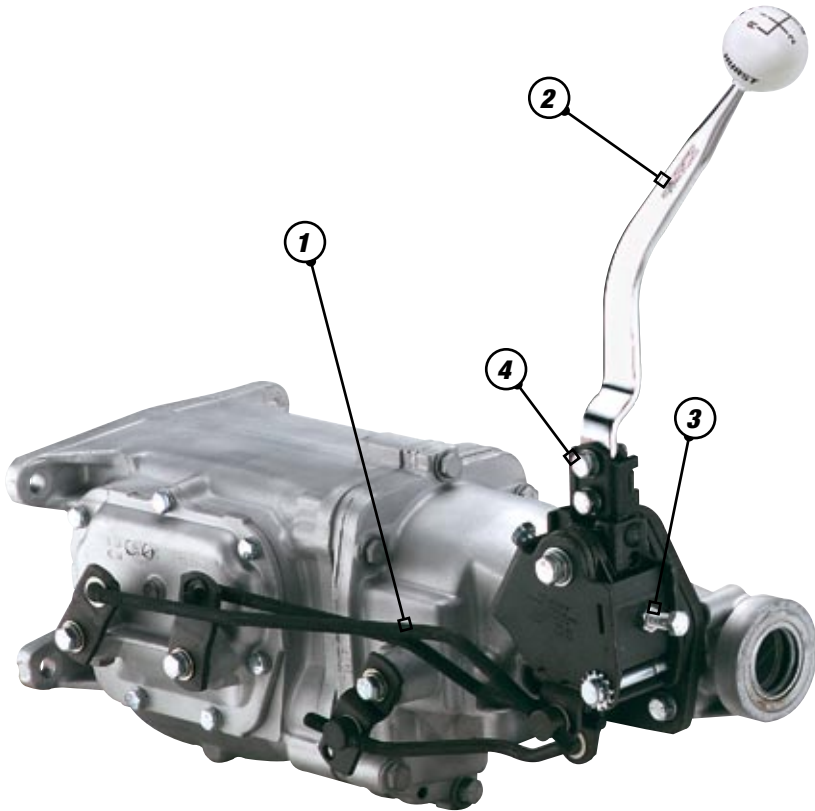

HURST MANUAL SHIFTER FEATURES

1. Complete installation hardware such as linkage rods and arms available and detailed installation instruction for a wide range of transmissions
2. Bolt-on chrome-plated or steel stick accepts classic Hurst knobs
3. Adjustable gear stops in most models prevent overshifts to help prolong transmission life
4. Most Hurst shifters accept various Hurst steel and chrome sticks for best ergonomic installation

HURST MANUAL SHIFTERS

HURST MANUAL SHIFTERS HAVE BEEN PART OF AMERICAN MUSCLE CAR HISTORY FOR OVER 50 YEARS. Hurst shifters are the shifter of choice for the ultimate transmission control for various 3, 4, 5 and 6-speed manual transmissions. Each application is carefully designed to shorten the throw appropriately and engineered to last.

Each Hurst shifter is built with race-track inspired design and reliability. With years of racing experience, you can count on uncompromising performance with each one of our lines of shifters.

EXTERNAL LINKAGE SHIFTERS

Pictured above is the famous Competition/Plus™ shifter. Designed with years of competition proven performance, it is mainly used on external linkage type transmissions.

INTERNAL RAIL SHIFTERS

Pictured to the above right is a Billet/Plus™ shifter, a modern design using billet materials for carriers. Typically installed and used in internal rail transmissions. Billet/Plus shifters are designed for the ultimate in strength, durability, and consistency.

TRANSMISSION SPECIFIC INDY SHIFTERS

Indy Shifters, pictured to the right, offer universal application appeal with unmistakable classic Hurst style at a value price. Applications are determined by transmission, not by vehicle.



A. '09+ Dodge Challenger 6 speed

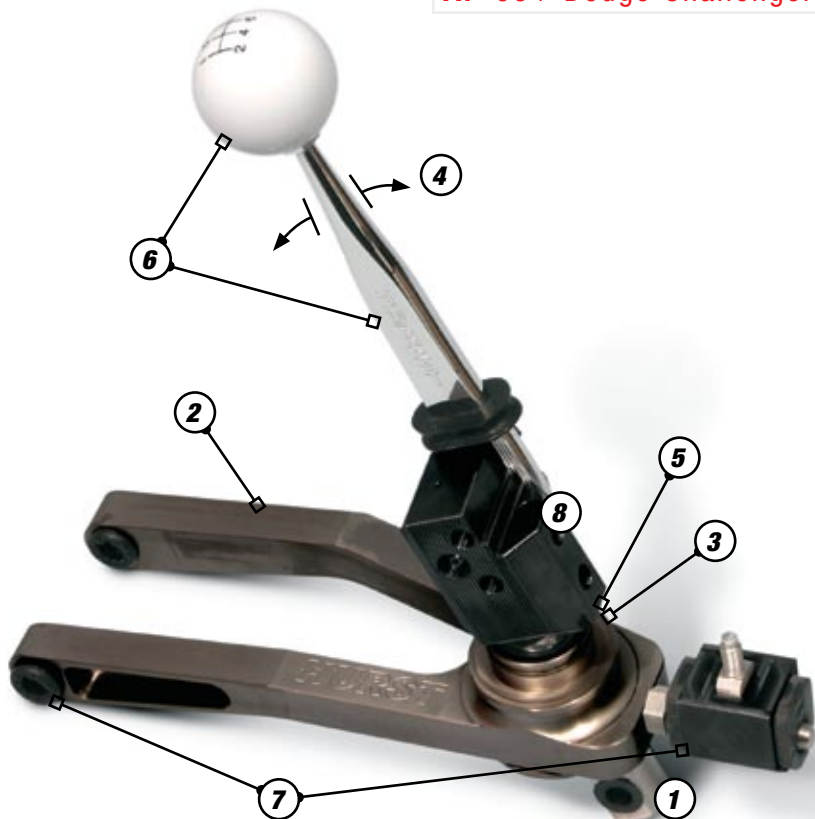

A. BILLET/PLUS SHIFTER 391 6020

1. CNC machined and heat treated chromoly steel lower stick assembly
2. CNC machined aluminum carrier arm
3. Teflon lined spherical pivot bearing
4. Shift throw reduced by 34% for quicker shifts
5. Smooth positive mechanism
6. Bolt on classic chrome plated stick and white knob
7. Front & Rear isolated mount assembly
8. CNC machined stainless steel stick adapter accepts Classic Hurst stick or OEM stick and Knob
9. Fully isolated shifter assembly

B. '10+ Chevrolet Camaro

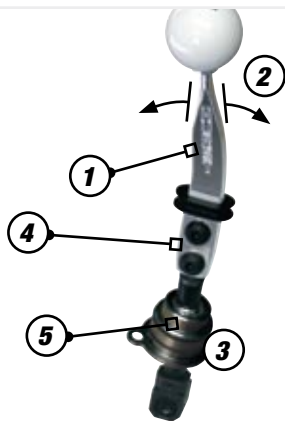

C. '11 Ford Mustang GT

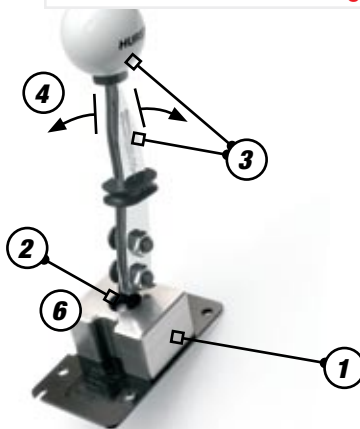

B. BILLET/PLUS SHIFTER 391 6030

1. Chrome stick and classic white knob
2. Shift throw reduced by up to 44%
3. CNC machined, Anodized titanium color aluminum base with properly relocated fulcrum
4. Interchangeable upper stick for custom handle and throw reduction
5. Teflon lined spherical pivot bearing

C. BILLET/PLUS SHIFTER 391 0204

1. CNC machined billet aluminum base
2. Spherical pivot bearing
3. Chrome stick & classic white knob
4. Shift throw reduced by up to 35%
5. Urethane rear mount bushing (not pictured)
6. Integrated and adjustable reverse lock-out detent eliminates push-down style lock-out

BILLET/PLUS SHIFTERS

UNCOMPROMISING SHIFT PERFORMANCE WITH ADVANCE ENGINEERING AND DESIGN, THE BILLET/PLUS LINE OF SHIFTERS IS THE BEST SHIFTER FOR YOUR LATE MODEL AMERICAN IRON. Hurst Billet/Plus Shifters incorporate a high ratio pivot mechanism for reduced shifter throw and are sturdily constructed for a more positive precise feel when shifting. Self centering alignment improves 2nd to 3rd up-shift gear changes to reduce the chance of "missed shifts". Patented adjustable bias spring loads on some models allow stick tension to be tailored to drivers preference. Dedicated applications assure a custom fit and eliminate any vehicle modifications for ease of installation.

A. BILLET/PLUS SHIFTER

391 5201

1. CNC machined billet aluminum arm
2. Spherical pivot bearing
3. Chrome stick & classic white knob
4. Shift throw reduced by 30%
5. Urethane front and rear bushings
6. Anodized titanium color finish

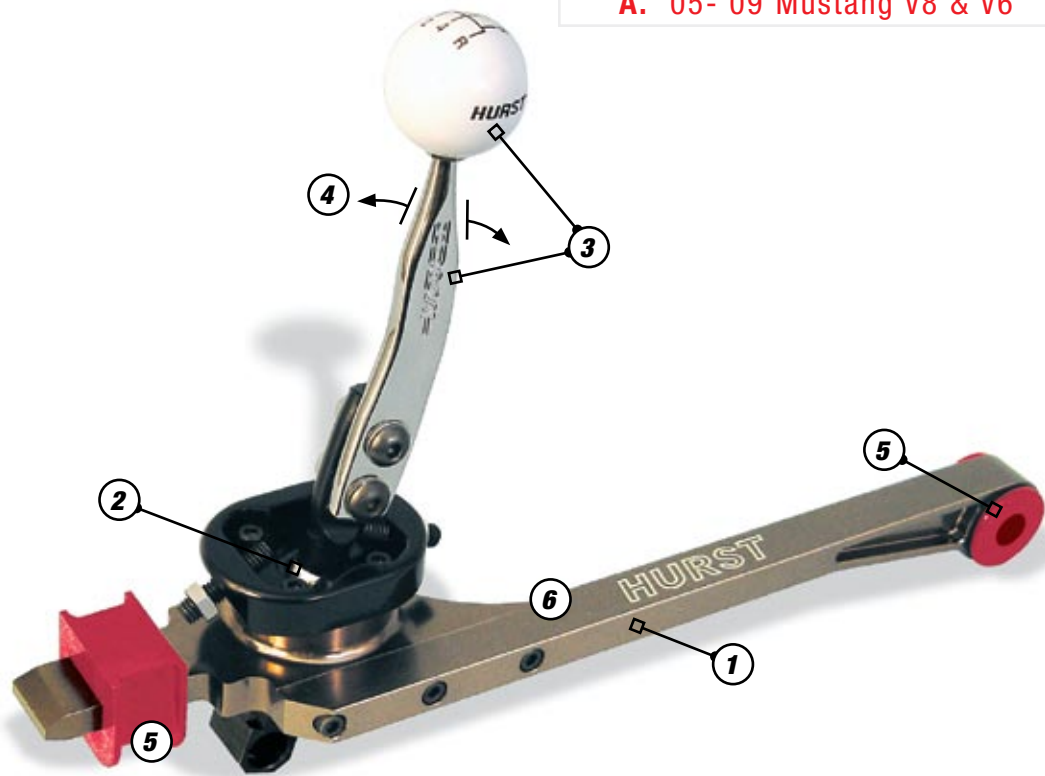

A. '05-'09 Mustang V8 & V6

B. COMPETITION/PLUS SHIFTER 391 5065

1. CNC machined billet aluminum pivot base
2. Spherical pivot bearing
3. Shift throw reduced by 30%
4. Chrome stick & classic black knob
5. Black stick included accepts factory knob (not pictured)
6. Unique Link Bar pivot assembly

COMPETITION/PLUS

COMPETITION/PLUS IS THE LEGENDARY HURST SHIFTER THAT HAS BEEN PART OF MUSCLE CAR HISTORY FOR OVER 50 YEARS! This shifter offers state of the art transmission control for popular 4, 5 & 6-speed manual transmissions. Dedicated applications assure a custom fit to a wide variety of vehicles having factory consoles without any floor pan modifications.

Features race track proven design and reliability, heat treated linkage rods and arms for added strength and durability, adjustable gear stops prevent overshifts to help prolong transmission life, and Bolt-on chrome-plated stick with attractive custom white knob with Hurst logo on the side and gear shift pattern on top.

B. '04-'06 Pontiac GTO

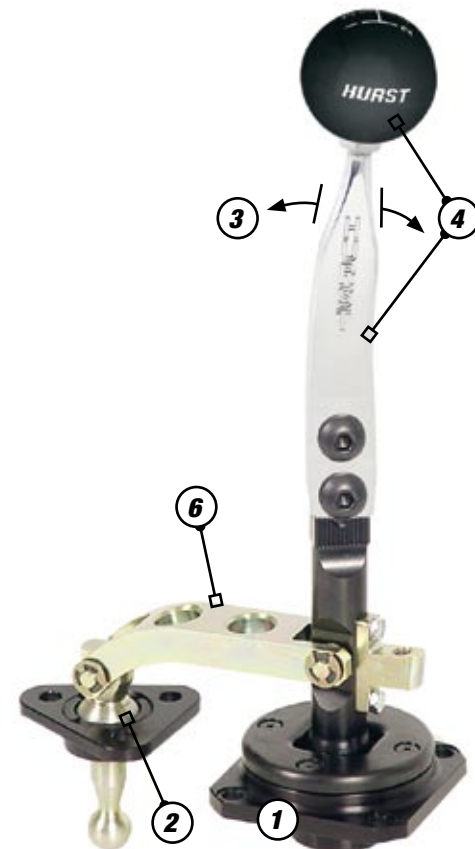

MANUAL SHIFTERS : COMPETITION/PLUS





A. '90-'98 Jeep Wrangler



SHIFTER APPLICATIONS FOR LIGHT TRUCKS AND UTILITY VEHICLES

THE TRADITIONAL HURST COMPETITION/PLUS SHIFTER AND BILLET/PLUS SERIES SHIFTERS ARE NOW AVAILABLE FOR MANY LATER MODEL PICK-UP TRUCKS & SUVs equipped with manual transmissions. This shifter is designed to provide a more positive and secure feel when shifting and incorporates a high ratio pivot mechanism for approximately 30% reduced knob travel resulting in shorter, quicker shifts. Patented adjustable bias spring loads allow stick tension to be tailored for driver's preference, and positive gear stops prevent overshifting and internal transmission damage. Supplied with chrome plated bolt-on stick with black knob and easily installed without any vehicle modifications.

Custom application shown here

A. JEEP BILLET/PLUS SHIFTER 391 5040

1. CNC machined 6061 T-6 BILLET ALUMINUM base and stop collar
2. High ratio pivot mechanism for approximately 30% reduced throw
3. Chrome plated stick.
4. Adjustable positive gear stops to help prevent internal transmission damage
5. Patented adjustable bias spring load for ease of operation
6. Classic black ball shift knob

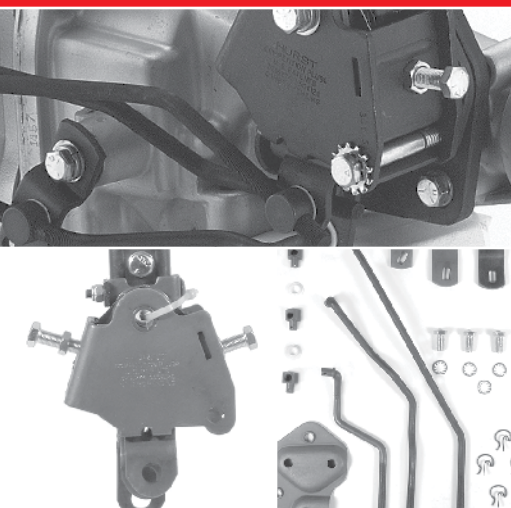

BUICK

MODEL	YEAR	DESCRIPTION	TRANSMISSION ³	SHIFTER	INST. KIT
Grand Sport	65	with and without console	Muncie (451)	391 7308	373 3163
	66-67	with and without console	Saginaw (441)	391 7307	373 4297
Skylark	65	with and without console	Muncie (451)	391 7308	373 3163
Special	66-67	with and without console	Saginaw (441)	319 7307	373 4297

CHEVROLET

MODEL	YEAR	DESCRIPTION	TRANSMISSION	SHIFTER	INST. KIT			
Full size	55-57	All	BW T-10 (410)	391 3780	373 4734			
			Richmond/BW T-10 (454)	391 3780	373 8609			
			Muncie (452/453)	391 3780	373 7834			
			Saginaw (441)	391 3780	373 7919			
			Muncie (451)	391 3780	373 3163			
	58-59	All	BW T-10 (410)	391 7307	373 3157			
			60-63	With and without console	BW T-10 (410)	391 7308	373 4734	
			63-64	With and without console	Muncie (451)	391 7308	373 3163	
			Camaro	67-68	With and without console	Saginaw (441)	391 4339	373 4531
						Muncie (451)	391 4339	373 4529
Camaro	69	With and without console	Muncie (452)	391 7438	373 7437			
			Muncie (453)	391 6848	373 7897			
	70-72	With and without console	Muncie (453)	391 8791	373 8605			
			Muncie (453)	391 8791	373 8605			
	73-74	With console	Saginaw (441)	391 7438	373 8607			
			Saginaw (441)	391 7438	373 8607			
	73-77	With console	Richmond/BW T-10 (454)	391 8794	373 8609			
			Richmond/BW T-10 (454)	391 8794	373 8609			
	74-81	Without console	Richmond/BW T-10 (454)	391 8791	373 8609			
			Richmond/BW T-10 (454)	391 8791	373 8609			
83-02	V6/V8	BW T-5 (464)	391 5032 ⁶ Billet/Plus	6				
		BW T-56 (468)	391 5060 ⁴ Billet/Plus	6				
93-02	V8	BW T-56 (468)	391 5061 ⁵ Billet/Plus	6				
		BW T-56 (468)	391 5061 ⁵ Billet/Plus	6				
2010+	V6/V8	Tremec TR-6060	391 6030 Billet/Plus	6				
Chevelle & Malibu	64 67	with and without console	Muncie (451)	391 7308	373 3163			
			Saginaw (441)	391 7307	373 4297			
	66-67	with and without console	Muncie (451)	391 8014	373 3163			
			Muncie (452/453)	391 8014	373 7834			
	68	with and without console	Muncie (453)	391 6848	373 7897			
			Saginaw (441)	391 8794	373 0017			
	69-72	with and without console	Muncie (453)	391 6848	373 7897			
Saginaw (441)			391 8794	373 0017				
Chevy II & NOVA	64	with and without console	Muncie (451)	391 7308	373 3163			
			Muncie (451)	391 7308	373 4354			
	65-67	with and without console	Muncie (451)	391 4339	373 4529			
			Muncie (451)	391 4339	373 4529			
	68	with console	Muncie (451)	391 6848	373 4529			
			Muncie (451)	391 6848	373 4529			
68	without console	Muncie (451)	391 6848	373 7131				
		Muncie (451)	391 6848	373 7131				
69-70	without console	Muncie (451)	391 6848	373 7131				
71-73	without console	Muncie (451)	391 6848	373 7834				

* Supplied with chrome plated steel stick and black knob.

Continued on next page



CHEVROLET (continued)					
MODEL	YEAR	DESCRIPTION	TRANSMISSION³	SHIFTER	INST. KIT
Corvette	57-62	All	BW T-10 (410)	391 7535	373 3157
	63-67	All	Muncie (451)	391 7960	373 3162
	68	All	Muncie (451)	391 7992	373 4648
	69-79	All	Muncie & BW (452/453 & 454)	391 7992	373 8611
	97-04	C5 V8	BW T-56	391 5085 ⁴ Billet/Plus	⁶
	05-07	C6 V8	BW T-56	391 5086 ⁴ Billet/Plus	⁶
El Camino	59	All	BW T-10 (410)	391 7307	373 3157
	64-67	with and without console	Muncie (451)	391 7308	373 3163
	66-67	with and without console	Saginaw (441)	391 7307	373 4297
	68	with and without console	Muncie (451)	391 8014	373 3163
	68-72	with and without console	Saginaw (441)		373 7919
	69-72	with and without console	Muncie (452/453)	391 8014	373 7834
	74	with console	Muncie (453)	391 6848	373 7897
	78-80	with and without console	Saginaw (441)	391 8794	373 0017
Monte Carlo	70-72	with and without console	Muncie (452/453)	391 8014	373 7834
	78-80	with and without console	Saginaw (441)	391 8794	373 0017
1/2 Ton Chevrolet & GMC Pickups	Custom installation when using passenger car transmissions		Muncie (451)	391 0002	373 3163*
			Muncie (452/453)	391 0002	373 7834*
			Richmond/BW T-10 (454)	391 0002	373 8609*
			BW T-10 (410)	391 0002	373 4734*
			Saginaw (441)	391 0001	373 7919*
CHRYSLER					
MODEL	YEAR	DESCRIPTION	TRANSMISSION	SHIFTER	INST. KIT
Full Size	64-67	without console	New Process (422)	391 6788	373 4089
	66-67	with console	New Process (422)	391 6790	373 4089
DODGE					
MODEL	YEAR	DESCRIPTION	TRANSMISSION	SHIFTER	INST. KIT
Charger	66-72	without console	New Process (422)	391 6789	373 4089
	66-69	with console	New Process (422)	391 6790	373 4089
Challenger	09-	6-speed	Tremec TR-6060	391 6020	⁶
Coronet & Super Bee	65-72	with console	New Process (422)	391 6789	373 4089
	65-69	W/Console	New Process (422)	391 6790	373 4089
Full Size	65-69	with console	New Process (422)	391 6790	373 4089
Viper	92-09	V10	BW T-56 (468)	391 5055 ¹ Billet/Plus	⁶
FORD					
MODEL	YEAR	DESCRIPTION	TRANSMISSION	SHIFTER	INST. KIT
Fairlane & Torino	66-69	with and without console	Ford T & C (433)	391 3180	373 7638
	70-71	with and without console	Ford T & C (433)	391 3180	373 7638
	72-73	with and without console	Ford T & C (433)	391 3180	373 5587
Falcon	66-67	8 Cyl. with and without console	Ford T & C (433)	391 3180	373 7638
Mustang	65-69	289, 302, 351 V-8 with and without console	Ford T & C (433)	391 3180	373 7637
	67-69	390, 428, 429 V-8 with and without console	Ford T & C (433)	391 3180	373 5587
	70-73	302, 351 V-8 with and without console	Ford T & C (432)	391 3180	373 7637
	83-86	with console	BW T-5 (465)	538 0035 Comp Stick Kit—See Page 17 For Details	
	87-92	with and without console	BW T-5 (465)	538 0036 ⁷ Comp Stick Kit—See Page 17 For Details	
	05-10	V8 with console	Tremec TR-3650	391 0201 ⁸ Comp/Plus	⁶
	05-10	V8 with console	Tremec TR-3650	391 5201 ⁸ Billet/Plus	⁶
2011+	GT	Getrag MT-82	391 0204 Billet/Plus	⁶	
Ranchero	66-69	8 Cyl. with and without console	Ford T & C (433)	391 3180	373 7638
	70-71	with and without console	Ford T & C (433)	391 3180	373 7638
	72-73	6 & 8 Cylinder with and without console	Ford T & C (433)	391 3180	373 5587
Ranger	88-05	V6/4cyl w/M50D	5 Speed Manual	391 5020 (5) Billet/Plus	⁶

Continued on next page

1. Black anodized round steel stick - uses stock factory boot. 2. Injected molded top plate, boot, chrome plated steel flat stick short throw, vibration insulators included. 3. See pages 31-32 for trans code information. 4. Supplied with black steel stick without knob, threaded for factory knob. 5. Supplied with chrome-plated steel stick and black knob. 6. Not Required. 7. Black aluminum stick w/Black knob (*TT) - Torque Tube Tailhousing. *Modification to stick may be necessary to clear seat. A Hurst Super Boot is recommended for a professional looking installation. (Pt # 114 7494) 8. Supplied w/ chrome plated steel stick and white knob.

JEEP

MODEL	YEAR	DESCRIPTION	TRANSMISSION	SHIFTER	INST. KIT
Wrangler	90-98	I-6	AX-15	391 5040 ⁵ Billet/Plus	6
	99-04	I-4/I-6	New Venture 1500/3500 (466)	391 0140 ⁵	6

MERCURY

MODEL	YEAR	DESCRIPTION	TRANSMISSION	SHIFTER	INST. KIT
Comet & Cyclone	66-69	with and without console	Ford T & C (433)	391 3180	373 7638
Cougar	67-69	289, 302, 351 V-8 with and without console	Ford T & C (432)	391 3180	373 7637
	67-69	390, 428, 429 V-8 with and without console	Ford T & C (433)	391 3180	373 5587
	83-91	with console	BW T-5 (465)	391 0031 ¹	6
	83-91	V6/V8	BW T-5 (465)	391 5031 ⁴ Billet/Plus	6

OLDSMOBILE

MODEL	YEAR	DESCRIPTION	TRANSMISSION	SHIFTER	INST. KIT
F-85	64-65	with and without console	Muncie (451)	391 7308	373 3163
	66	without console	Muncie (451)	391 7308	373 3163
442	64-65	with and without console	Muncie (451)	391 7308	373 3163
	66	without console	Muncie (451)	391 7308	373 3163
	78-79	with and without console	Saginaw (441)	391 8794	373 0017
Cutlass	78-79	with and without console	Saginaw (441)	391 8794	373 0017

PLYMOUTH

MODEL	YEAR	DESCRIPTION	TRANSMISSION	SHIFTER	INST. KIT
Belvedere & GTX	65-72	without console	New Process (422)	391 6789	373 4089
Roadrunner	68-72	without console	New Process (422)	391 6789	373 4089

PONTIAC

MODEL	YEAR	DESCRIPTION	TRANSMISSION	SHIFTER	INST. KIT
Full Size	60-64	without console	BW T-10 (410)	391 7308	373 4734
Firebird	67-68	with and without console	Saginaw (441)	391 4339	373 4531
	67-68	with and without console	Muncie (451)	391 4339	373 4529
	69	with and without console	Muncie (452)	391 7438	373 7437
	70-72	with and without console	Muncie (452/453)	391 6848	373 7897
	74-81	without console	BW T-10 (454)	391 8794	373 8609
	74-81	with console	BW T-10 (454)	391 8791	373 8609
	83-92	V6/V8	BW T-5 (464)	391 5032 ⁷ Billet/Plus	6
	93-02	V6	BW T-5 (464)	391 5032 ⁷ Billet/Plus	6
	93-02	V8	BW T-56 (468)	391 5060 ⁴ Billet/Plus	6
	93-02	V8	BW T-56 (468)	391 5061 ⁵ Billet/Plus	6
Grand Prix	78-79	with and without console	Saginaw (441)	391 8794	373 0017
G.T.O.	64-66	without console	Muncie (451)	391 7308	373 3163
	04-06	with console	BW T56 (468)	391 5065	6
Tempest & Lemans	64-66	without console	Muncie (451)	391 7308	373 3163
	66	without console	Saginaw (441)	391 4339	373 4531
	78-79	with and without console	Saginaw (441)	391 8794	373 0017
Ventura II	71-73	without console	Muncie (453)	391 6848	373 7834

SHELBY MUSTANG

MODEL	YEAR	DESCRIPTION	TRANSMISSION	SHIFTER	INST. KIT
GT-350	65-69	with and without console	BW T-10 (413)	391 3180	373 3668
GT-500	67-69	with and without console	FORD T & C (433)	391 3180	373 5587

STUDEBAKER

MODEL	YEAR	DESCRIPTION	TRANSMISSION	SHIFTER	INST. KIT
Hawk	59-64	w/ Bucket Seats	BW T-10 (410)	391 7308	373 4734

1. Black anodized round steel stick - uses stock factory boot. 2. Injected molded top plate, boot, chrome plated steel flat stick short throw, vibration insulators included. 3. See pages 31-32 for trans code information. 4. Supplied with black steel stick without knob, threaded for factory knob. 5. Supplied with chrome-plated steel stick and black knob. 6. Not Required. 7. Black aluminum stick w/Black knob (**TT) - Torque Tube Tailhousing.



A. Street Super/Shifter 4-speed

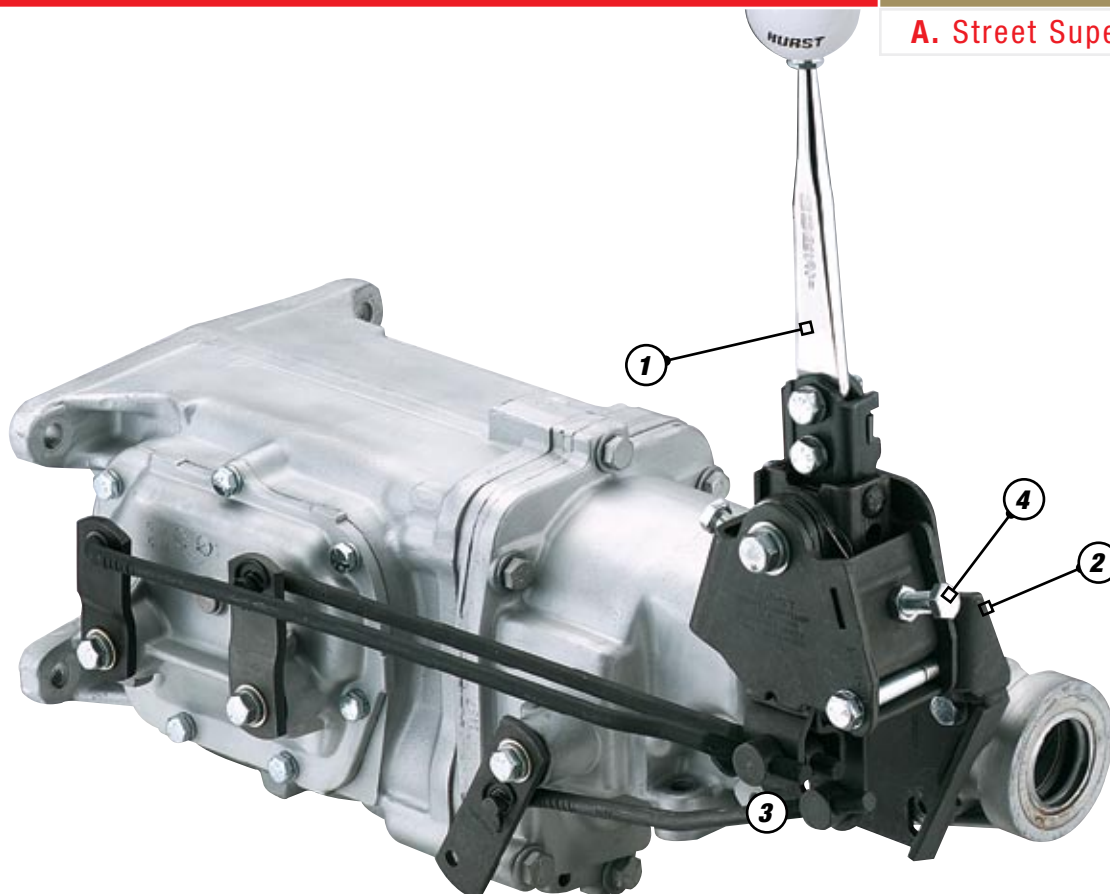

69+ Muncie shown here with 373 8616 Installation kit

STREET SUPER/SHIFTER 4-SPEED

BASED ON THE RACING VERSION OF THE LEGENDARY SUPER SHIFTER 3, the Hurst Street Super/Shifter brings many of the same quality features to a new level of performance.

Street Super/Shifter comes complete with all necessary hardware and easy to follow installation guide. Shifter assembly and installation kit each sold separately.

Optional bolt-on sticks available for custom vehicle applications. See pages 30

Optional Hurst Super Boot #114 7494 recommended for finished appearance and sold separately.

NOTE: Street Super/Shifters are not vehicle specific. They will fit the transmissions listed, but will not fit stock consoles and often require minor floor pan modification for installation.

STREET SUPER/SHIFTER

TRANSMISSION	SHIFTER	INST. KIT
Muncie (451, 452, 453)	391 7535	373 8616
BW T-10 (410)	391 7535	373 8616
Richmond/BW Super T-10 (454)	391 7535	373 8616
Saginaw (441)	391 7535	373 8618
Ford T&C (432, 433)	391 7535	373 8615

A. STREET SUPER/SHIFTER 4-SPEED 391 7535

1. Utilizes a 7-1/2" tall chrome-plated stick (3/8-16 thread) for a short throw, 4-3/4" knob travel between gears.
2. High mounting design assures proper linkage rod alignment.
3. Heat treated components for extra strength and reliability.
4. Adjustable gear stops to prevent overshifts.

A. MASTERSHIFT 3-SPEED 366 6809

1. Exclusive advanced gear shift mechanism design for shorter throw and positive, precise shifts
2. Heat treated components for durability and longer life
3. Attractive chrome-plated steel stick with 3/8-16 thread and custom white knob
4. Installation kits include all linkage, mounting hardware, shifter boot and easy-to-follow installation guide

A. Mastershift 3-speed

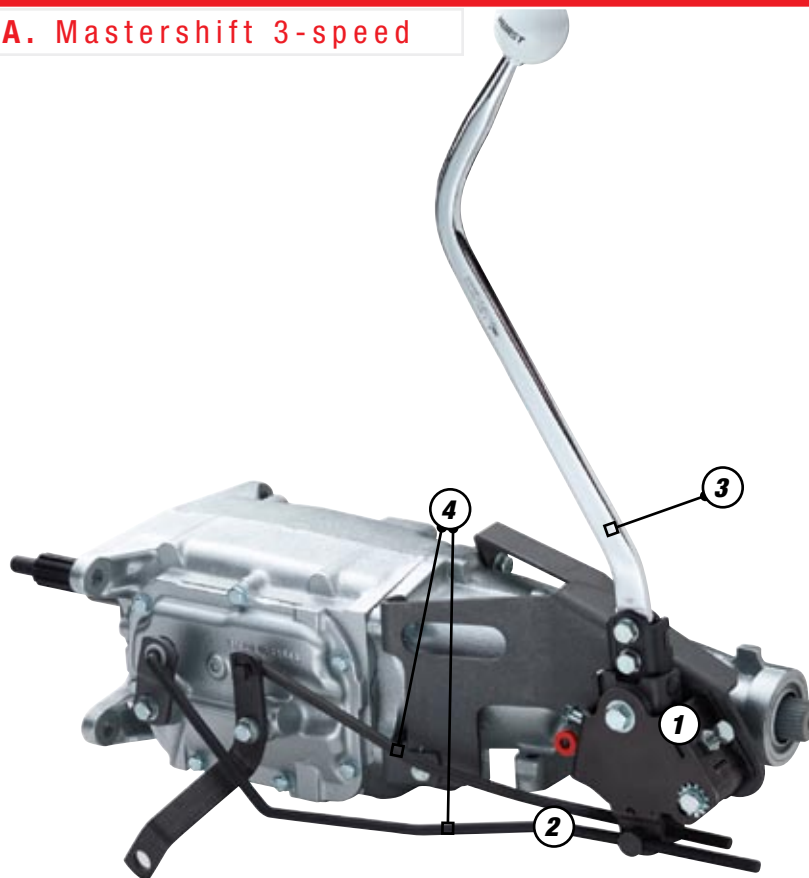

MASTERSHIFT 3-SPEED

HURST'S MASTERSHIFT 3-SPEED SHIFTER IS DESIGNED TO PROVIDE PRECISE GEAR SELECTION AND DEPENDABLE LONG LIFE. Popular as both a replacement floor shift and a column shift conversion. Shifter assembly and installation kit each sold separately.

BUICK

MODEL	YEAR	DESCRIPTION	TRANSMISSION	SHIFTER	INST. KIT
Gran Sport and Special	66-67	6 & 8 Cylinder without console	Saginaw (343)	366 7271	367 0010

CHEVROLET

MODEL	YEAR	DESCRIPTION	TRANSMISSION	SHIFTER	INST. KIT
Chevelle	66-72	6 & 8 Cylinder without console	Saginaw (343)	366 7271	367 0010
	73-74	6 & 8 Cylinder without console	Saginaw (343)	366 7271	367 0010
	73-74	6 & 8 Cylinder without console	Saginaw (343)	366 7271	367 0010

FORD

MODEL	YEAR	DESCRIPTION	TRANSMISSION	SHIFTER	INST. KIT
Bronco	66-77	8 Cylinder - Only	Ford T & C (333)	366 6901	367 0013
Pick-Up 1/2 Ton	63-87	All 2 Wheel Drive*	Ford (333)	366 6809	367 0027

OLDSMOBILE

MODEL	YEAR	DESCRIPTION	TRANSMISSION	SHIFTER	INST. KIT
Cutlass F-85 & 442	66-72	6 & 8 Cylinder without console	Saginaw (343)	366 7271	367 0010



MANUAL SHIFTERS : MASTERSHIFT 3-SPEED

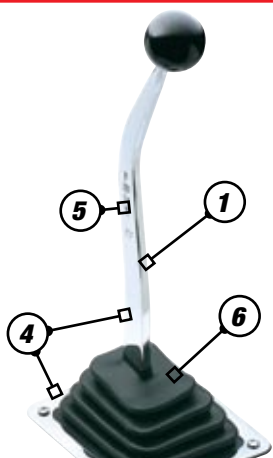

A. Indy Truck 3-Speed

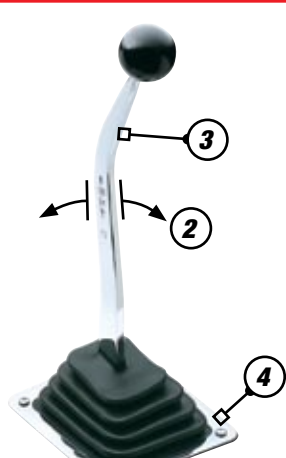

B. Indy SSA



C. Universal Indy

**A. INDY PICK-UP TRUCK 3-SPEED SHIFTER
501 0016**

1. Extended chrome-plated stick (uses 3/8-24 thread) to accommodate truck seat height
2. Precise selector pin mechanism (not pictured)
3. Spring loaded gate for positive shifts (not pictured)
4. All parts plated for protection
5. Stamped with Hurst/Indy identification
6. Shown with optional Indy Boot & Plate #114 8429 recommended for finished appearance

B. INDY SSA SHIFTER 501 0002

1. Spring loaded gate for positive shifts (not shown)
2. Short precise throws for less stick travel
3. Attractive chrome plated stick (3/8-24 thread) can be adjusted to different positions
4. All components are plated for protection. Kit includes boot and plate

**C. UNIVERSAL 4-SPEED INDY SHIFTER
503 0030**

1. Narrow spring-loaded gate for ease of operation (not pictured)
2. Heat-treated and plated parts for added strength and durability
3. 7-1/2" tall chrome-plated stick (3/8-16 thread) provides short, precise throws
4. Shown with optional Hurst Boot #114 8429

NOTE: The high mounting location of these kits often eliminates their use with factory consoles. Trim modifications to floor pans are often necessary.

INDY PICK-UP TRUCK 3-SPEED SHIFTER

THIS POPULAR INDY SHIFTER IS AVAILABLE FOR PICK-UP TRUCKS and is a perfect replacement for old floor shifters, or an ideal column shift conversion. Fits many popular pickup trucks with 3-speed manual transmissions and comes complete with all linkage, mounting hardware, and easy to follow installation guide.

INDY PICK-UP TRUCK #501 0016

MAKE	YEAR
GENERAL MOTORS All two-wheel drive with Saginaw, Muncie & Tremec transmissions	69 & Later
FORD MOTOR CO. All two-wheel drive with Ford & Tremec transmissions	63 & Later

INDY SSA SHIFTER

Ideal for floor shift replacement or column shift conversion, fits most popular passenger cars with 3-speed manual transmissions. Complete with shifter boot, hardware and easy to follow instructions.

INDY SSA UNIVERSAL #501 0002

MAKE	YEAR
Buick*	64 & Later
Chevrolet-Standard & H.D. 6 & 8 cylinder	55 & Later
Chevelle, Camaro, Chevy II	62 & Later
Oldsmobile-Standard & Intermediates*	49 & Later
Pontiac-Standard & H.D.*	58 & Later
Pontiac Firebird, Tempest & LeMans	64 & Later
Chrysler, Plymouth, Dodge Standard & Intermediate (except Duster, Demon, Challenger - not for trucks)	57 & Later
Ford & Mercury Standard	49 & Later
Fairlane, Montego, Torino, Meteor, Falcon, Comet	62 & Later

*Will fit all 6 cyl., HD and standard 3-speed transmissions except selector type gear boxes (single shaft). Certain applications require a great deal of modification to make shifter fit.

INDY UNIVERSAL 4-SPEED SHIFTER

HURST/INDY 4-SPEED SHIFTER KITS ARE DESIGNED TO BE USED ON MOST POPULAR 4-SPEED TRANSMISSIONS and a wide variety of cars. Applications are determined by transmissions and an exclusive engineered mounting design, making them adaptable to many popular passenger car floor pans. Comes complete with all hardware, linkage and easy-to-follow instruction guide.

INDY UNIVERSAL 4 SPEED

TRANSMISSION APPLICATIONS	PART NUMBER
Muncie (451, 452 & 453), BW T-10 (410, 454), Super T-10 AS3 & AS9	503 0030
Saginaw (441)	503 0033
Ford T & C (432, 433)	503 0031

See pgs 34-35 for transmission ID chart

A. PRO BILLET SUPER/SPEEDWAY SHIFTER 491 0500

1. BILLET ALUMINUM housing for reduced weight
2. CNC-machined components ensure precision tolerances
3. Blanchard ground selector levers for smoother positive shifting
4. Heat-treated BILLET STEEL selector pin and levers provide strength, reliability & longevity
5. Push-down reverse prevents accidental engagement (not pictured)
6. Stainless steel fasteners are drilled for safety lock wire.

This shifter is designed to be used with custom fabricated linkage Shifter stick and linkage is not included. See pages 36 for custom stick selection.

A. Pro Billet Super/Speedway

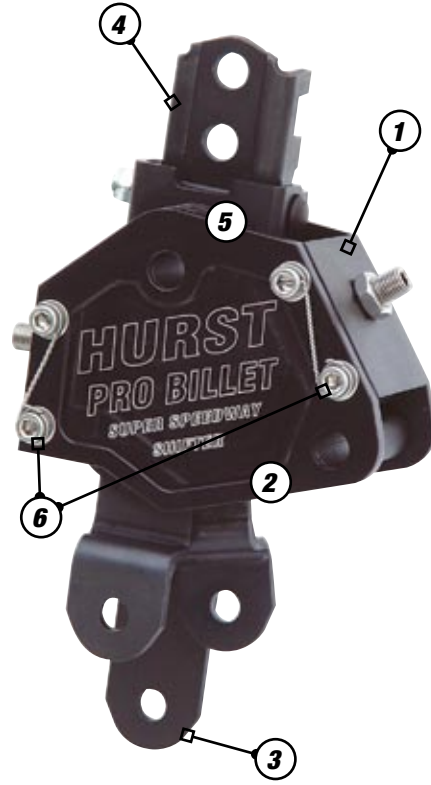

PRO BILLET SUPER/SPEEDWAY SHIFTER FRAME

DESIGNED FOR FAST, SMOOTH, POSITIVE GEAR CHANGES, THIS NEW AND IMPROVED 4-SPEED SHIFTER IS AN EXCELLENT CHOICE FOR DRAG OR CIRCLE TRACK RACING and can be specifically tailored to driver comfort by utilizing Hurst's extensive line of bolt-on steel sticks.





HURST AUTOMATIC SHIFTER FEATURES

1. Reverse Loc/Out for NHRA and IHRA requirements
 2. Classic Hurst knob or t-handle available for most shifters
 3. Simple one-handed operation
- * See page 24-25 for list of available Hurst knobs and t-handles
- ** Custom application shown here

HURST AUTOMATIC SHIFTERS

LEGENDARY HURST PERFORMANCE FINALLY COMES TO AUTOMATIC SHIFTERS! Award winning innovative design combined with Hurst style and functionality, Hurst automatic shifters provide ultimate automatic transmission control for both street and race applications.

Shifter applications are transmission specific, and shifter operation is simple and intuitive. Choose the Pro-Matic or V-Matic line-up for street performance or Quarter Sticks for your competition needs.

PRO-MATIC 2™

Classic Hurst stick and knob style wrapped in an attractive and functional automatic shifter package! The Pro-Matic 2 line of Hurst automatic shifters offers race inspired performance in a ratchet style shift action. Simple, one handed operation that fits most domestic 2, 3, and 4 speed automatic transmission applications.

V-MATIC 2™

One of a kind “dual mode” automatic shifter, the V-Matic 2 offers both ratchet style shift action and in-line gate style shifting that gives you the best of both worlds. Use the in-line gate style shifting for leisurely cruise, or switch to ratchet style shifting for all-out racing action.

Stylish Hurst handle compliment any interior, and attractive black textured console can be modified to fit a wide range of applications.

THE ORIGINAL QUARTER STICK® AND QUARTER STICK 2

The original still has it! Small, compact, light-weight but durable, the Quarter Stick is the perfect application for a tight, confined cockpit like a drag car, or drag car with rear engine application (Quarter Stick 2), or even street cars with custom interior and limited fitment. Weighing in at a scant 2.5 pounds, the Quarter Stick still provides solid, positive gear changes that eliminates over-shift.

PISTOL-GRIP QUARTER STICK®

Same great features as the Original Quarter Stick, but with a beautiful, ergonomic pistol grip for a more natural and comfortable shifting position.

COMP STICK KIT

Dress up your modern day electronically controlled transmissions with our Hurst Comp Stick Kit! Kit comes with CNC machined console plate engraved with the Hurst logo, Hurst engraved chrome stick sleeve, and a classic Hurst knob. Threaded chrome stick sleeve will accept other classic Hurst knobs or t-handle.

PRO-MATIC 2™ RATCHET SHIFTER

1. Full forward and reverse ratchet action can be used with either standard or reverse pattern valve bodies

OPERATION OF SHIFTER FROM PARK:

From the park position, lift up on handle and pull back into reverse. From reverse pull back into neutral, push down and ratchet into gear.

OPERATION OF SHIFTER FROM DRIVE GEAR:

Ratchet into neutral. Pull up on handle and push into reverse. From reverse, pull up on handle and push into park.

2. Cable-operated to provide your choice of mounting locations
3. Progressively illuminated gear position indicator
4. Incorporates a neutral safety and back-up light switch assembly
5. Attractive black textured console with chrome-plated top cover can be trimmed to fit any floor contour
6. Chrome-plated stick and a black knob (3/8-16 thread) give the shifter a custom look
7. Complete with hardware, heavy-duty 5' long shifter cable, and easy to follow installation guide
8. Positive reverse Loc/Out for NHRA and IHRA requirements

A. Pro-Matic 2 for Cars



B. Pro-Matic 2 for Trucks

PRO-MATIC 2 RATCHET SHIFTER

THE HURST PRO-MATIC 2 RATCHET ACTION SHIFTER IS QUALITY ENGINEERED FOR YEARS OF PRECISE, TROUBLE-FREE OPERATION. The Pro-Matic 2 gives a custom appearance to any vehicle and is ideal for street or strip performance.

The Pro-Matic 2 for trucks incorporates an extended shifter stick for ease of operation and is designed to fit most pick-up trucks.



PRO-MATIC 2 APPLICATIONS

MAKE	TRANSMISSION	CAR APPLICATION	TRUCK APPLICATION
GM	TH 250, 350, 375, 400	383 8500	383 8510
GM	62-73 Powerglide (Alu. case)	383 8505	
Ford	C-4, C-6 and AOD	383 8500*	383 8510*
Mopar	Torqueflite A727-A904	383 8500	383 8510
AMC	Torque Command A727-A904	383 8500	383 8510

* Will fit AOD with B&M #40496 lever & bracket kit.



A. V-Matic 2 #383 8520

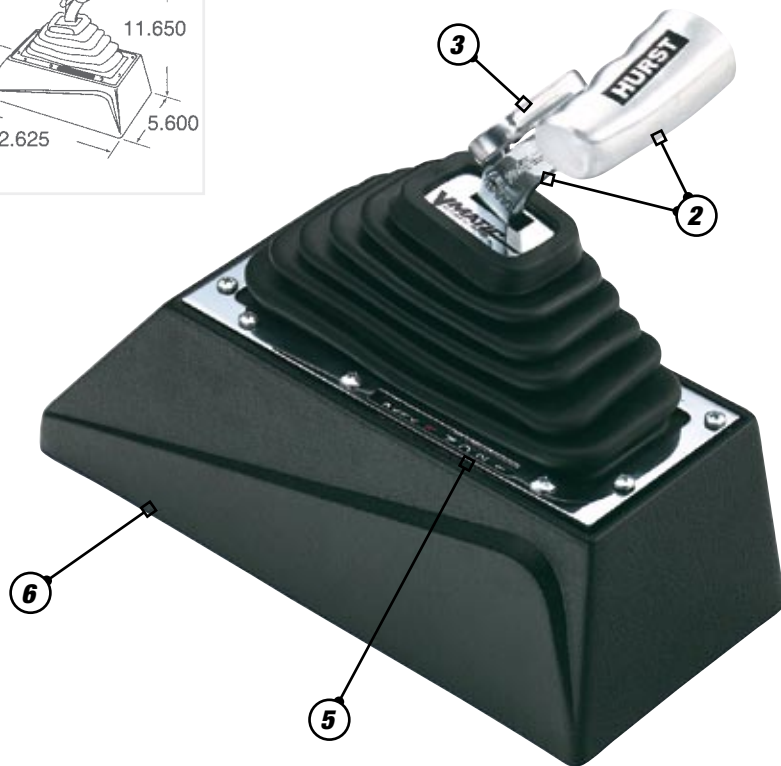
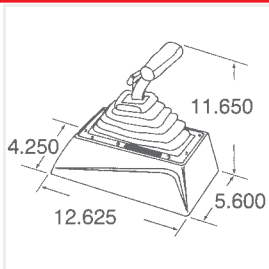

V-MATIC 2™ DUAL MODE SHIFTER

1. Dual mode operation for street performance or all out racing.

IN-LINE GATE MODE:

From the park position, pull up on the reverse Loc/Out handle. Pull back into reverse, push down and simply pull back into neutral or desired gear.

RATCHET MODE:

From the park position, pull up on the reverse Loc/Out handle and move into reverse. Push down and pull back to neutral. Push down in neutral and ratchet into gear.

- 2. Highly polished shifter lever and brushed aluminum Hurst T-handle (3/8-16 thread).
- 3. Trigger operated reverse Loc/Out for NHRA and IHRA requirements.
- 4. Incorporates a neutral safety and back-up light switch assembly.
- 5. Progressively illuminated gear position indicator.
- 6. Attractive black textured console with chrome-plated top cover can be trimmed to fit any floor contour.
- 7. Complete with all hardware, heavy-duty 5' long shifter cable, and easy to follow installation guide.
- 8. Cable operated to allow multiple install locations on the floor

B. V-Matic 2 #383 8525

V-MATIC 2 DUAL MODE SHIFTER

PRO-MATIC 2 APPLICATIONS

MAKE/TRANSMISSION	APPLICATION
GM TH 250,350, 400	383 8520
GM 62-73 Powerglide (Aluminum case)	383 8525
Ford C-4, C-6 and AOD	383 8520*
Mopar Torqueflite A727 and A904	383 8520
AMC Torqueflite A727 and A904	383 8520

* Will fit AOD with B&M #40496 lever & bracket kit.



A. THE ORIGINAL QUARTER STICK®

1. Designed for 2, 3 and 4-speed automatic transmissions in both forward and reverse valve body shift patterns
2. Extremely compact and lightweight for tight fit cockpit installation and weighs only 2.5 pounds
3. Comes with factory installed neutral safety switch (back-up light switch is available separately)
4. Controlled gate stop provides positive gear changes eliminating overshifts
5. One-hand operated, spring loaded reverse Loc/Out mechanism enables drivers to clear the reverse Loc/Out while remaining strapped in their shoulder harness belts
6. Forged aluminum stick for added strength has 7/16-20 thread
7. Cable operated
8. Optional covers (sold separately)

A. The Original Quarter Stick



B. QUARTER STICK 2™

1. Rear exit cable for easier installation, positive shifts and less potential cable binding
2. Designed for 2 and 3-speed transmissions in both forward and reverse valve body shift patterns
3. Comes complete with hardware, and 5' long shifter cable, and easy to follow installation guide
4. Forged aluminum stick for added strength has 7/16-20 thread
5. Other features are the same as the Quarter Stick Automatic Shifter
6. Positive reverse Loc/Out for NHRA and IHRA requirements

B. Quarter Stick 2

THE ORIGINAL QUARTER STICK

THE AWARD-WINNING QUARTER STICK AUTOMATIC SHIFTER is designed to provide positive gear change control for street or racing transmission applications.

QUARTER STICK 2

Based on the original Quarter Stick technology, this ultimate drag racing shifter is ideal for rear engine dragsters.



*Shown with optional cover 130 0056 (sold separately)

QUARTER STICK SHIFT GATE PATTERNS

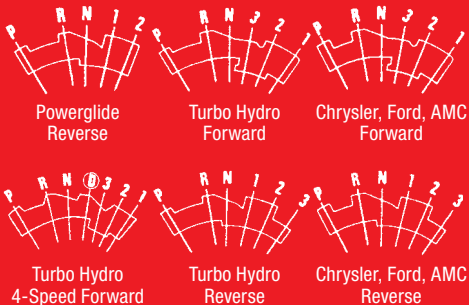

QUARTER STICK APPLICATIONS

TRANSMISSION	VALVE BODY	QUARTER STICK
Powerglide (Alum. case only)	Forward & Reverse	316 0001
TH 250, 350, 375 & 400	Forward	316 0006
TH 250, 350, 375 & 400	Reverse	316 0001
Chrysler/AMC A727, A904	Forward	316 0009
Ford C-4, C-6	Forward	316 0009
Chrysler/AMC A727, A904	Reverse	316 0014
Ford C-4, C-6	Reverse	316 0014

QUARTER STICK 2 APPLICATIONS

TRANSMISSION	VALVE BODY	QUARTER STICK 2
Powerglide	Forward & Reverse	316 0020
TH 250, 350, 375 & 400	Reverse	316 0020



A. Pistol-Grip Quarter Stick

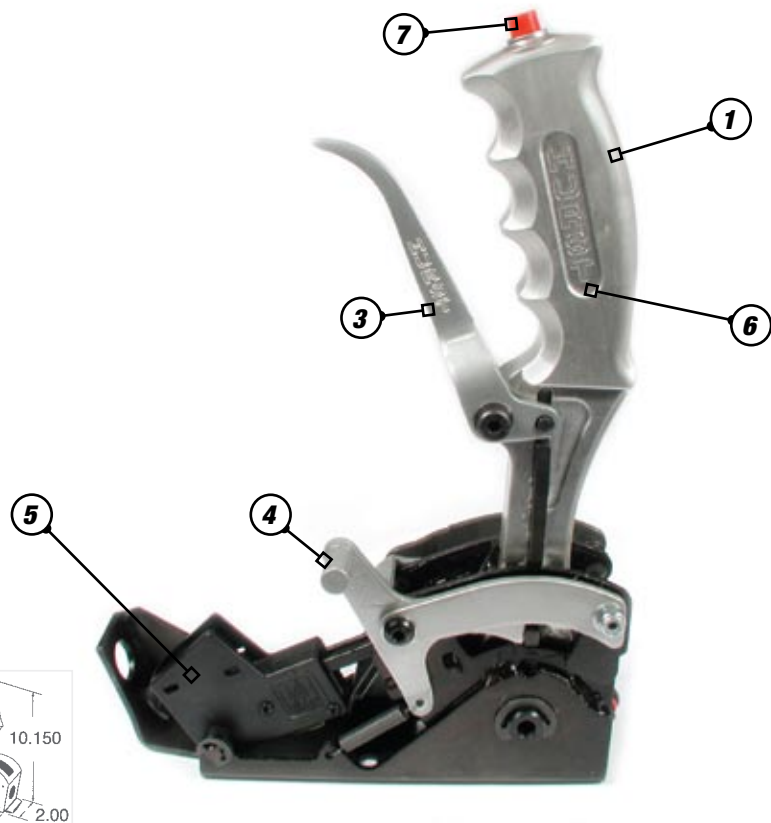

B. Pistol-Grip Quarter Stick 2



PISTOL-Grip QUARTER STICK

THE HURST PISTOL-Grip QUARTER STICK SHIFTER IS DESIGNED FOR A FIRM COMFORTABLE NATURAL GRIP, PROVIDING A POSITIVE FEEL WHEN SHIFTING. This shifter has all of the same award winning features and qualities of our existing Quarter Stick automatic shifter, including controlled detent activation, one-hand operated spring loaded reverse Loc/Out mechanism, and neutral safety switch. The pistol-grip handle is CNC-machined

from billet aluminum for exceptional strength, and features a precision snap-action switch that is ideal for operating a Hurst Roll/Control, nitrous system or trans brake.

PISTOL-Grip QUARTER STICK APPLICATIONS

TRANSMISSION	VALVE BODY	PISTOL-Grip QUARTER STICK
Powerglide (Alum. case only)	Forward & Reverse	316 2001
TH 250, 350, 375 & 400	Forward	316 2006
TH 250, 350, 375 & 400	Reverse	316 2001
Chrysler/AMC A727, A904	Forward	316 2009
Ford C-4, C-6	Forward	316 2009
Chrysler/AMC A727, A904	Reverse	316 2014
Ford C-4, C-6	Reverse	316 2014

PISTOL-Grip QUARTER STICK 2 APPLICATIONS

TRANSMISSION	VALVE BODY	PISTOL-Grip QUARTER STICK 2
Powerglide	Forward & Reverse	316 2020
TH 250, 350, 375 & 400	Reverse	316 2020

PISTOL-Grip QUARTER STICK®

1. Firm comfortable natural grip, providing a positive feel when shifting
2. All of the same award winning features and qualities of our existing Quarter Stick automatic shifter
3. Controlled detent activation
4. One-hand operated spring loaded reverse Loc/Out mechanism
5. Neutral safety switch
6. Pistol-grip handle is CNC-machined from billet aluminum for exceptional strength,
7. Precision snapaction switch ideal for operating a Hurst Roll/Control, nitrous system or trans brake.

PISTOL-Grip QUARTER STICK2™

1. Rear exit cable for easier installation, positive shifts and less potential cable binding
2. Designed for 2 and 3-speed transmissions in both forward and reverse valve body shift patterns
3. Comes complete with hardware, and 5' long shifter cable, and easy to follow installation guide
4. Forged aluminum stick for added strength
5. Other features are the same as the Pistol-Grip Quarter Stick Automatic Shifter
6. Positive reverse Loc/Out for NHRA and IHRA requirements

QUARTER STICK SHIFT GATE PATTERNS

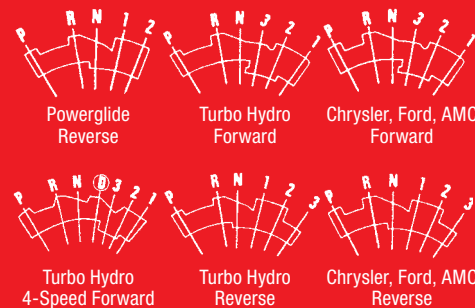

A. ALUMINUM COVER KIT 130 0041

Adds a professional finished look to your Quarter Stick or Pistol Grip installation. Attaches to shifter with quick release pins (included) and may be used in conjunction with the aluminum mounting plate kit. Does not fit Quarter Stick 2 or Pistol Grip 2.

B. PLASTIC COVER KIT

Adds a distinctive finished look to your Quarter Stick™ installation. Mounting plate and button head screws are included with the plastic cover kit.

Quarter Stick/Pistol Grip 130 0055

Quarter Stick 2/Pistol Grip 2 130 0056

C. ALUMINUM MOUNTING PLATE KIT

Clear anodized aluminum mounting plate offers mounting flexibility and allows quick shifter removal via quick release pins (included).

Mounting Plate 195 0225

Replacement Pin 189 0082

D. BACK-UP LIGHT SWITCH 248 8601

Kit includes back-up light switch and hardware. Easy installation for all Quarter Stick and Pistol Grip shifters having front cable exit.

E. NEUTRAL/PARK START SAFETY SWITCH 248 8600

Kit includes switch and mounting hardware. Easy installation for all existing Quarter Sticks. (Newer Quarter Sticks and Pistol Grip shifters feature the switch installed from the factory.) Fits front and rear exit cable shifters.

F. "SIDEWINDER" SHIFT KNOB 163 0070

The "Sidewinder" shift knob is equipped with a side button switch conveniently located for driver hand comfort, which can be used for Roll/Control or nitrous operation. 7/16"-20 thread size.

G. COMPETITION SHIFTER KNOB WITH BUILT-IN 12 V SWITCH 163 0050

Now with snap action for instant activation, this black molded ABS knob is ideal for use with Hurst Roll/Control®, trans brake, nitrous oxide systems or other 12 volt accessories. 7/16 x 20 thread size, application for Quarter Stick.

H. SOLENOID SHIFTING KIT 226 0020

The Hurst Electric Solenoid Shifting Kit is designed to automatically complete the 1st to 2nd gear change, increasing shifting reliability and improving E.T. consistency.

- Engineered for forward pattern Hurst Quarter Sticks
- Shifting is controlled when used with an rpm activated switch or manually activated push button (normally open) switch.
- The solenoid features a spring activated plunger, and is designed to quickly and firmly push the shifter stick into gear, not "hit" or "slam" it, which can cause damage to the stick itself.
- Kit includes a H.D. 12-volt solenoid rated at maximum 3-amp draw to hold the plunger in position, aluminum mounting bracket, hardware, fuse and electrical connectors.

A. Aluminum Cover Kit



B. Plastic Cover Kit



C. Aluminum Mounting Plate Kit



D. Back-up Light Switch



E. Neutral/Park Start Safety Switch



F. "Sidewinder"



G. Comp Knob



H. Solenoid Shifting



QUARTER STICK : ACCESSORIES



A. Paddle-Shift for Camaro



A. PADDLE-SHIFTER FOR 2010+ CAMARO

1. Easy to install mechanism, does not require removal of steering wheel or airbag
2. Interchangeable paddles for customized look
3. Retains factory TapShift® button, no rewiring
4. Paddles adjustable for best ergonomic comfort
5. Ergonomically designed paddles
6. Tough yet flexible mounting bracket

B. PADDLE-SHIFTER FOR 2008+ CHALLENGER

1. No steering wheel modifications required
2. Does not require removal of steering wheel for wiring or power
3. Adjustable paddle mounting position
4. Injection molded paddles

B. Paddle-Shift for Challenger



PADDLE-SHIFT KITS

WE PUT THE CONTROL OF YOUR TRANSMISSION AT THE TIP OF YOUR FINGERS. The Hurst Paddle-Shift kits are easy to install, easy to operate, and best of all, no need to remove sensitive airbag nor complicated steering wheel!

Rip through the gears like professional drivers while keeping your hands on the steering wheel at all times! Paddle-shift applications are available for 2010+ Chevrolet Camaros and 2008+ Dodge Challengers, Chargers*, Magnums*, and Chrysler 300s* with automatic transmission.

PADDLE-SHIFT APPLICATIONS

MAKE	MODEL	YEAR	APPLICATION
Chevrolet	Camaro	2010+	538 5430 "Jagan" style aluminum paddle kit
			538 5431 "Jagan" aluminum paddles only
			538 5432 Standard style Delrin® paddle kit
			538 5433 Standard style Delrin® paddles
Dodge	Challenger	2008+	538 5400
	Charger*	2008+ with AutoStick	538 5400
	Magnum*	2008+ with AutoStick	538 5400
Chrysler	300*	2008+ with AutoStick	538 5400

* Vehicles equipped with AutoStick feature.

A. COMP STICK AND PLATE KIT 2010+ CAMARO

1. CNC machined billet console plate
2. Integrated pistol trigger retains factory Park/Reverse lock-out operation
3. Stylish HardDrive stick
4. Black anodized plate for a durable finish
5. Dual LED lighted indicator windows and location points (included)
6. Engraved Hurst logo
7. No console modification necessary

A. Comp Plate & Stick Kit, 2010+ Camaro



B. COMP PLATE KIT '10+ FORD MUSTANG

1. CNC machined billet console plate
2. Retains use of OE indicator window
3. Black anodized for a durable finish
4. Engraved Hurst logo
5. No console modification necessary

C. COMP STICK KIT '08+ DODGE CHALLENGER

1. CNC machined billet console plate
2. Stainless steel Hurst engraved handle sleeve
3. Classic Hurst knob
4. Anodized black finish
5. Engraved Hurst logo
6. Retains "AutoStick" feature on Chrysler LX platform vehicles
7. No console modification necessary

C. Comp Stick Kit for 08+ Challenger



D. Polished Comp Stick Kit, Challenger



COMP STICK KIT

DON'T FEEL LEFT OUT IF YOU HAVE ONE OF THE NEWER MODERN TRANSMISSIONS WITH ELECTRONICALLY CONTROLLED GEARBOXES, or if you just want to dress up your OEM console. You can still modify your LX platform based Chrysler and Dodge automatics, 2010 or later Chevrolet Camaros, or late generation Mustang with the Hurst Comp Stick Kit.



B. Comp Plate kit, 2010+ Mustang



D. POLISHED COMP STICK KIT '08+ DODGE CHALLENGER

Seeking a little more flare for your interior? Have some chromed or polished bits already added? Try the POLISHED Comp Stick kit. This kit comes with a white knob with the Hurst logo prominently displayed on top, and the plate polished to a mirror like finish to ensure your interior stands out like few other.

E. COMP STICK KIT '08+ CHRYSLER 300, DODGE CHARGER, DODGE MAGNUM

Same great features as the other comp stick kit, with specific application for 2008 or later Chrysler/Dodge LX platform cars with AutoStick®.

F. POLISHED COMP STICK KIT '05-'07 CHRYSLER 300, DODGE CHARGER, DODGE MAGNUM

Fits 2005-2007 Chrysler/Dodge LX platform vehicles with AutoStick®.

E. Comp Stick Kit, '08+ LX Platform



F. Comp Stick Kit, '05-'07 LX



APPLICATION

YEAR	MAKE AND MODEL	FINISH	APPLICATION
'10+	Chevrolet Camaro – Plate assembly only	Black anodized	538 0430
'10+	Chevrolet Camaro – Stick assembly only	Titanium anodized handle	538 0431
'10+	Chevrolet Camaro – Stick assembly only	Black Delrin® handle	538 0433
'10+	Chevrolet Camaro – Plate and stick	Titanium anodized handle	538 0432
'10+	Chevrolet Camaro – Plate and stick	Black delrin handle	538 0434
'08 +	Dodge Challenger	Black anodized	538 0402
'08 +	Dodge Challenger	Polished	538 0403
'08 +	Chrysler 300, Dodge Magnum and Dodge Charger (with AutoStick feature)	Black anodized	538 0404
'08 +	Chrysler 300, Dodge Magnum and Dodge Charger (with AutoStick feature)	Polished	538 0405
'05 – '07	Chrysler 300, Dodge Magnum and Dodge Charger (with AutoStick feature)	Black anodized	538 0410
'05 – '07	Chrysler 300, Dodge Magnum and Dodge Charger (with AutoStick feature)	Polished	538 0411
'83 – 86	Ford Mustang w/factory Console & T-5 Trans	Black anodized	538 0035
'87 – 93	Ford Mustang w/factory Console & T-5 Trans	Black anodized	538 0036
'10+	Ford Mustang – Plate assembly only	Black anodized	538 0420
'10+	Ford Mustang – Stick assembly only	Titanium anodized handle	538 0421
'10+	Ford Mustang – Stick assembly only	Black delrin handle	538 0423
'10+	Ford Mustang – Plate and stick	Titanium anodized handle	538 0422
'10+	Ford Mustang – Plate and stick	Black delrin handle	538 0424

A. Original Roll/Control

A. THE ORIGINAL ROLL/CONTROL®

174 5000

1. Advanced quality design stainless steel valve assembly for ultimate corrosion resistance
2. Fully enclosed epoxy molded electrical coil for reliability
3. Attractive finned aluminum housing helps dissipate heat
4. Wider lightweight base provides better mounting stability
5. 150 micron screen filtered ports to prevent contamination
6. Field serviceable for cleaning or rebuilding to original factory specifications
7. Extra threaded port for separate bleeder or brake line pressure gauge
8. Kit includes solenoid valve, snap-action switch, indicator light, 4-amp fuse, mounting screws and installation instructions
9. 12-volt negative ground systems only

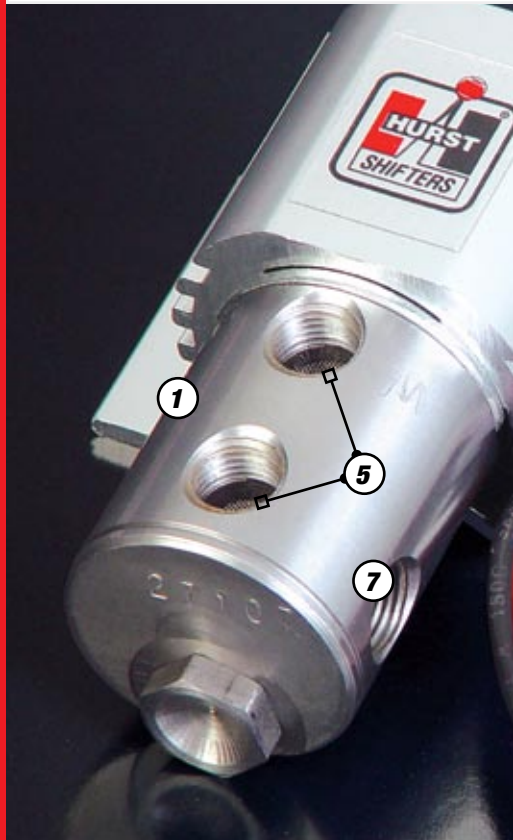

B. Roll/Control Adapter Fitting Kit

B. ROLL/CONTROL ADAPTER FITTING KITS

These adapter fitting kits simplify the installation of a Roll/Control or Line/Loc system into late model Camaro, Firebird or Mustang vehicles having metric threaded brake line fittings. Designed to be used with the Hurst Roll/Control Installation Kit #567 1510, these kits consists of special conversion fittings needed for an easier installation.

THE ORIGINAL ROLL/CONTROL

USED PRIMARILY IN DRAG RACING TO PROVIDE POSITIVE LOCKING ACTION TO THE FRONT WHEELS OF RACE CARS, reducing the chance of "Rolling the Lights" and producing more effective "Burn Outs" for heating up the tires. Rigorous testing has proved a 1/100,000 of a second release time and vibration tests have seen up to 30 G's applied without mechanical failure. Adaptable to most domestic and import hydraulic brake systems.



CAUTION: The Hurst Roll/Control or Line/Loc® should not be used as an emergency brake, or any application requiring the solenoid to be activated for a long period of time.

ROLL/CONTROL REPLACEMENT PARTS

Roll/Control Rebuild Kit	567 1500
Solenoid only	566 7550

ROLL/CONTROL ADAPTER FITTING KITS APPLICATION

MAKE/MODEL	YEAR	PART NUMBER
Chevrolet Camaro/Pontiac Firebird	93-02	567 1515
Chevrolet Corvette	85-96	567 1515
Ford Mustang w/oBosch ABS	83-11	567 1516

COMPLETE ROLL/CONTROL KIT FOR MODERN MUSCLE CAR APPLICATIONS

MAKE/MODEL	YEAR	PART NUMBER
Dodge Challenger	08-10	567 1517
	2011+	567 1520
Chevrolet Camaro	2010+	567 1518
Ford Mustang	05-09	567 1521
	2010+	567 1519



A. Roll/Control Installation Kit



B. Spiral Cord w/ High-Speed Switch



C. NEW! Roll/Control Switch Kit



A. ROLL/CONTROL INSTALLATION KIT 567 1510

The Roll/Control Installation Kit is designed to be used in conjunction with most brake holding devices on American made vehicles. This kit contains brake lines and various brass fittings, connectors, adapters, unions and plugs necessary for an easy installation.

B. SPIRAL CORD WITH HIGH-SPEED SNAP ACTION SWITCH 248 3880

This precision snap-action switch is ideal for operating Roll/Controls, nitrous systems, trans brakes, etc. The switch is designed to provide instantaneous, smooth operation under the most severe racing conditions.

- Low contact resistance for instantaneous response
- High shock resistance
- Moisture and dust proof for marine and off-road racing
- Epoxy sealed contacts and terminals
- 6' (18 gauge) coil cord for mounting in almost any location
- 10 amp. capacity
- Normally open

C. NEW! ROLL/CONTROL SWITCH KIT 248 8376

A new, modern looking Roll/Control switch kit! A separate "arming" switch with a lighted activation button will ensure ease of use and proper function of your Roll/Control, as well as a clean and inconspicuous installation.

ROLL/CONTROL ACCESSORIES

THESE ACCESSORIES ALLOW THE INSTALLATION OF THE ORIGINAL ROLL/CONTROL IN VARIOUS DOMESTIC MAKES AND MODELS. Replacement switches, spiral cord with switches, knobs and pistol-grip handles with switches can all be used in conjunction with The Original Roll/Control. Applications listed below.

ROLL/CONTROL INSTALLATION KIT	
Roll/Control installation kit	567 1510
ROLL/CONTROL SWITCH	
Replacement Switch for Hurst Roll/Control	248 3875
SPIRAL CORD WITH HIGH-SPEED SNAP ACTION SWITCH	
Spiral cord with high-speed snap action switch	248 3880
COMPETITION SHIFTER KNOB WITH BUILT-IN 12-VOLT SWITCH	
THREAD SIZE	PART NO.
3/8 x 16"	163 0049
7/16 x 20"	163 0050
MODERN ROLL/CONTROL SWITCH KIT	
Switch kit with lighted activation button & arming switch	248 8376

A. SHIFTER KNOBS

1. Original Hurst Classic design
2. Solid high gloss, high strength plastic
3. Engraved inlaid shift pattern
4. 1-3/4" diameter, except as noted (2-1/4" knobs are vehicle application specific)
5. Molded-in brass thread insert
6. Complete with jam nut

B. REPLACEMENT SHIFTER KNOBS

1. Solid high gloss plastic knob with "Hurst" name
2. Molded-in metal thread insert, complete with jam nut

C. SIDEWINDER KNOBS

The "Sidewinder" shift knob is equipped with a side button switch conveniently located for driver hand comfort, which can be used for Roll/Control or nitrous operation.

1. Features a HD quick release "normally open" 12V switch 10 amp
2. 2-1/4" diameter white knob available with engraved shift pattern for 5-speed Mustang w/12mm x 1.75 thread, 6-speed Camaro/Firebird w/16mm x 1.50 thread and 6-speed Corvette C5 w/9/16-18 thread
3. 2" diameter black knob with Hurst logo for all Hurst Quarter Stick shifters with 7/16"-20 thread and Hurst Comp/Plus chrome plated shifter sticks having 3/8"-16 thread

D. COMPETITION KNOBS WITH SWITCH

1. Features a heavy-duty, quick release 12 volt normally open switch w/24" long wire lead, 10 amp
2. Ideal for use w/Roll/Control, trans brake, nitrous, etc
3. Solid plastic knob w/jam nut
4. Quality die cast aluminum T-handles

A. Shifter Knobs



B. Replacement Shifter Knobs



C. Sidewinder Knobs



D. Competition Knobs with Switch



SHIFTER KNOBS

CLASSIC SHIFTER KNOBS (without Hurst script engraved on side)

THREAD SIZE	4 SP WHITE	4 SP BLACK	5 SP WHITE	5 SP BLACK	6 SP WHITE	6 SP BLACK
3/8-16	163 0003	163 0103	163 0008	163 0108	163 0040	163 0140
3/8-24	163 0002					
7/16-20	163 0004					
9/16-18 Corvette C5					*163 0056	*163 0156
12mm x 1.75 Mustang			*163 0014	*163 0114	*163 0060	*163 0160
16mm x 1.50 Camaro/FB					*163 0016	*163 0116

Hurst Classic Knobs are 1.75" in diameter unless otherwise noted. Knobs marked with * are 2.25" in Diameter.

REPLACEMENT CLASSIC SHIFTER KNOBS (with Hurst script engraved on side)

THREAD SIZE	3 SP WHITE	4 SP WHITE	5 SP WHITE	5 SP BLACK	QUARTER STICK WHITE
3/8-16	163 7624	163 7626	163 0025	163 0125	
7/16-20					163 1036

SIDEWINDER SHIFT KNOBS

12 mm x 1.75 Mustang (white) 5-Speed ('79-'04)	163 0051
16mm x 1.50 Camaro/Firebird (white) 6-Speed	163 0052
3/8"-16 thread (black) Hurst logo (Comp/Plus, Pro Matic)	163 0069
7/16"-20 thread (black) Hurst logo (Quarter Stick)	163 0070**

Sidewinder knobs are 2.25" in diameter unless otherwise noted. Knobs marked with ** are 2" in Diameter.

COMPETITION KNOBS WITH BUTTON

3/8"-16 thread	163 0049
7/16"-20 thread	163 0050

SHIFTER ACCESSORIES : KNOBS



A. Pistol Grip Handle and Stick



B. Pistol-Grip Handle w/ Switch



C. Pistol-Grip Handle



A. PISTOL GRIP HANDLES & STICKS

1. Available for 1970-74 'B' & 'E' body Mopars
2. For Console and non-Console applications
3. Simulated woodgrain handle and angled lever are ideal replacements for original equipment

B. PISTOL-GRIP SHIFTER HANDLE WITH 12-VOLT SWITCH

CNC machined from solid billet aluminum with a natural finish, the Hurst Pistol-Grip Shifter Handle is designed to provide a firm comfortable natural grip when shifting, allowing less chance of your hand slipping and missing a shift. Equipped with a 12-volt 10 amp capacity normally open snap action switch which can be used for activating a Roll/Control, nitrous or other accessory. One part number fits stock factory shifters in both Mustang w/ 12mm x 1.75 thread and Camaro/Firebird w/ 16mm x 1.50 thread as well as the Hurst Billet/Plus shifters for these applications

C. PISTOL-GRIP SHIFTER HANDLE

CNC machined from solid billet aluminum, the Hurst Pistol-Grip Shifter Handle is designed to provide a firm comfortable natural grip when shifting, allowing less chance of your hand slipping and missing a shift. Available in natural aluminum finish or an attractive black anodized finish with the Hurst name engraved in contrasting letters

PISTOL GRIPS

PISTOL GRIP HANDLE AND STICK (with 4 speed patterns)

APPLICATION	PART NUMBER
70-74 E-body, 71-74 B-body console (11.5" tall)	538 8575
71-74 B-body non-console (15" tall)	538 8580
70 B-body non-console (20.25" tall)	538 8585

PISTOL-GRIP SHIFTER HANDLE WITH 12-VOLT SWITCH

THREAD SIZE	PART NO.
Clear anodized – UNIVERSAL*	153 6200
Black anodized – UNIVERSAL*	153 6210

* Includes 3/8-16, 1/2-20, M10-1.25, M10-1.50, M12-1.25, M12-1.75, M16-1.50

PISTOL-GRIP SHIFTER HANDLE

THREAD SIZE	ALUMINUM FINISH	BLACK ANODIZED
Universal*	153 1000	153 6010

* Includes 3/8-16, 1/2-20, M10-1.25, M10-1.50, M12-1.25, M12-1.75, M16-1.50

A. POLISHED T-HANDLE WITH BUTTON

1. 12v switch for Roll/Control, nitrous or other accessories
2. Polished aluminum finish
3. Bold HURST identification
4. With SAE and Metric jam nuts and adapters

B. UNIVERSAL HURST T-HANDLES

1. Quality die cast aluminum
2. Brushed or chrome finish
3. Bold HURST identification
4. Complete with adapters & jam nut
5. SAE fits 1/4"-28, 5/16"-18, 3/8"-16, 1/2"-20
6. Metric fits 7mm x 1.00, 8mm x 1.25, 10mm x 1.50, 12mm x 1.50

C. HURST LOGO T-HANDLE

Made of solid die-cast aluminum for strength and durability, this nostalgic T-Handle features a 4-speed shift pattern embossed within the bold Hurst "H" logo.

1. Attractive brushed satin finish accented with a black inlaid background for a great look
2. Fits all Hurst Comp/Plus chrome plated shifters sticks having 3/8"-16 threads
3. Includes jam nut

A. T-Handle with Button



B. Universal T-Handles



C. Hurst Logo T-Handle



T-HANDLES

T-HANDLES

APPLICATIONS	THREAD SIZE	FINISH	PART NUMBER
Universal T-Handles	SAE 1/4"-28, 5/16"-18, 3/8"-16, 1/2"-20	Chromed	153 0032
	Metric 7mm x 1.00, 8mm x 1.25, 10mm x 1.50, 12mm x 1.50	Chromed	153 0033
Hurst Logo T-Handle	SAE and Metric	Brushed	153 0020**
	SAE and Metric	Polished	153 0040**
T-Handle w/ Button	3/8"-16	Brushed	153 5000
	SAE and Metric	Brushed	153 0010**
	SAE and Metric	Polished	153 0011**

** Includes SAE 3/8"-16, 7/16"-20, 1/2"-20, and Metric M10-1.25, M10-1.50, M12-1.25, M12-1.75, M16-1.50

THREAD SIZE CHART

HURST SHIFTERS	THREAD SIZE	HURST SHIFTERS	THREAD SIZE	OEM SHIFTERS	THREAD SIZE
Aluminum sticks	7/16"-20	Indy Pick Up Truck	3/8"-24	Camaro 5 & 6 speed internal rail w/OEM stick	16mm x 1.50
Auto/Stick 1	3/8"-16	Indy Qualifier	3/8"-16	Firebird 5 & 6 speed internal rail w/OEM stick	16mm x 1.50
Auto/Stick 3	3/8"-16	Indy SSA	3/8"-24	Mustang 5 & 6 speed internal rail w/OEM stick ('79-'04)	12mm x 1.75
Billet/Plus w/chrome stick	3/8"-16	Pro-Matic, before 1987	1/2"-13	Mustang '05-'10	12mm x 1.25
Billet/Plus w/black stick	Factory OE Thread Size	Pro-Matic 2, since 1987	3/8"-16	Corvette 6-speed 89-04	9/16"-18
Chrome replacement sticks	3/8"-16	Quarter/Stick & Q/S 2	7/16"-20	Viper	1/2"-20
Comp/Plus (early)	3/8"-24	Quick/Stick	Factory OE Thread Size	B&M Shifters and most automatic shifters	1/2"-20
Comp/Plus (late), & OEM	3/8"-16	Super Shifter 3	3/8"-16		
Dual/Gate 2	3/8"-16	Vertical Gate, before 1987	1/2"-13		
Indy 3 Speed	3/8"-24	V-Gate 2, since 1987	3/8"-16		
Indy Matic 1	3/8"-24	V-Matic, before 1987	1/2"-13		
		V-Matic 2, since 1987	3/8"-16		



A. HardDrive Stick Tall



A. HARDDRIVE STICK TALL

These new HardDrive handles are a modern rendition of our classic pistol grip design. Originally designed only for Hurst Performance Vehicles, these ergonomic and stylish handles are now available in a brushed aluminum, anodized titanium, or black Delrin® finish. **These handles will attach to any Hurst shifter that accepts a two bolt style upper stick.** The stick is polished billet aluminum for maximum strength and durability, the brushed finish and anodized titanium finish are both machined out of aluminum, while the black Delrin handle offers endless customization possibilities. Includes billet aluminum boot support.

Taller stick designed for use with Billet/Plus or Comp/Plus with tall upper stick requirements, such as 2008+ Dodge Challenger. Although taller stick may also be used with Hurst shifters with shorter upper stick requirement for ergonomic purposes*.

* By using a taller upper stick shift leverage as well as throw reduction will be altered.

B. HARDDRIVE STICK SHORT

Shorter stick designed for use with Billet/Plus or Comp/Plus with shorter upper stick requirements, such as 2010+ Chevrolet Camaro or 2005+ Ford Mustang. Includes billet aluminum boot support.

B. HardDrive Stick Short



Titanium Anodized



Brushed Aluminum



Black Delrin®

HARDDRIVE STICKS

THESE HARDDRIVE STICKS WERE SO POPULAR WITH THE HURST PERFORMANCE VEHICLES, we just had to make them for everyone else to enjoy! Both size sticks come with three available grip finishes.

HARDDRIVE HANDLE

APPLICATION	PART NUMBER
Black Delrin handle, tall	538 8651 (See sidebar for application)
Brushed Aluminum handle, tall	538 8660 (See sidebar for application)
Anodized Titanium handle, tall	538 8650 (See sidebar for application)
Black Delrin handle, short	538 8656 (See sidebar for application)
Brushed Aluminum handle, short	538 8665 (See sidebar for application)
Anodized Titanium handle, short	538 8655 (See sidebar for application)

ALUMINUM BOOT SUPPORT

APPLICATION	PART NUMBER
Billet aluminum boot support (fits any Hurst flat stick)	114 0521

SHIFTER ACCESSORIES : HARDDRIVE STICK

SHIFTER BOOTS

A. B-4 BOOT & PLATE

Our most popular boot is adaptable to most shifter installations. Complete with chrome trim plate and mounting hardware.

Measures 5-1/4" x 6-1/2", 4 pleats **114 4580**

B. B-1 BOOT & PLATE

Designed for use with round stick shifters. Complete with chrome ID plate and mounting hardware.

Measures 4-3/8" x 5-3/8", 3 pleats **114 7336**

C. INDY BOOT & PLATE

A popular economy boot. Complete with chrome trim plate and mounting hardware.

Measures 5-1/4" x 6-1/2", 4 pleats **114 8429**

D. SUPER BOOT & PLATE

Designed for large hole shifter installations. Complete with chrome ID plate and mounting hardware.

Measures 7-3/4" x 8-3/4", 6 pleats **114 7494**

E. SUPER/SHIFTER 3 BOOT & PLATE

Specially designed for use with Super/Shifter 3 utilizing separate reverse Loc/Out lever. Complete with chrome trim plate and mounting hardware.

Measures 7-3/4" x 8-3/4", 6 pleats **114 0010**

A. B-4 Boot & Plate



B. B-1 Boot & Plate



C. Indy Boot & Plate



D. Super Boot & Plate



E. Super/Shifter 3 Boot with Plate



SHIFTER BOOTS

MATCH THESE STYLISH HURST SHIFTER BOOTS TO YOUR SPECIFIC APPLICATION, or use it to customize a console installation.

SHIFTER ACCESSORIES : BOOTS



A. Hurst Performance Wheels



A. HURST PERFORMANCE WHEELS

Hurst Performance Wheels like the ones that came on the Hurst Performance Vehicles for your 2005+ Mustang, 2008+ Challenger, and 2010+ Camaro! Lightweight, pressure cast wheels in 20" diameter with bolt pattern, bore, and offset designed specifically for your vehicle! Stylish, functional, and priced right, these polished wheels with matte gun-metal grey inserts will set apart your American Muscle from the garden variety appliance your neighbors drive!

* PLEASE NOTE: These wheels require additional lug-nuts to fit to your Challenger. 91147HTB-5 from Gorilla Accessories or equivalent.

B. HURST EQUIPPED EMBLEM 136 1000

Based on original HURST blueprints, this HURST EQUIPPED emblem is an authentic reproduction of the one used on the late '60's muscle cars equipped with a factory Hurst shifter. Made of durable ABS plastic with 3M adhesive tape backing for permanent mounting. Nominal size is 1-1/4" high by 5 -1/4" long. Individually packaged.

B. Hurst Equipped Emblem



C. BACK-UP LIGHT SWITCH 248 0003

This switch is designed to be used in conjunction with the OEM back-up lights and the Competition/ Plus 4-Speed, Super/Shifter 3 and the Master Shift 3-Speed shifters.

C. Back-up Light Switch



D. Auto Transmission Swap Kit

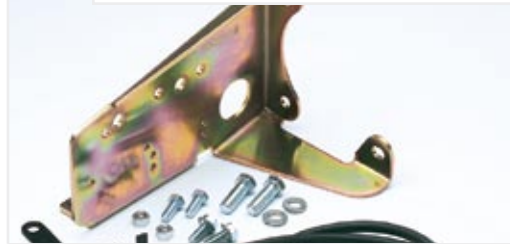

D. AUTOMATIC TRANSMISSION SWAP KITS FOR CAMARO, FIREBIRD

Installing a Turbo-Hydro 350 in your '82-'91 Camaro or Firebird has just been made easier with a new transmission swap kit from Hurst Performance. Designed to assist in replacing the stock automatic or manual transmission in V8 applications, these kits eliminate having to fabricate custom brackets and adapters, allowing for a relatively hassle-free, bolt-in installation. Each kit is complete with a new torque arm bracket, two transmission arms, cable brackets, spacers and related hardware. The TH 350 kit utilizes the stock OEM crossmember.

ACCESSORIES

HURST PERFORMANCE WHEELS

2010+ Camaro FRONT, 20" x 9"	806031
2010+ Camaro REAR, 20" x 11"	806032
2008+ Challenger FRONT, 20" x 9"*	806021
2008+ Challenger REAR, 20" x 10"*	806022
2005+ Mustang FRONT. 20" x 9"	800201
2005+ Mustang REAR, 20" x 10"	800202

HURST EQUIPPED EMBLEM

Hurst equipped emblem	136 1000
-----------------------	----------

BACK-UP LIGHT SWITCH

Back-up light switch	248 0003
----------------------	----------

AUTOMATIC TRANSMISSION SWAP KITS FOR CAMARO, FIREBIRD

MAKE/MODEL	YEAR	TRANS.	PART NO.
Camaro/Firebird	'82-'91	TH 350	550 0001

A. HURST NOSTALGIA II T-SHIRT, BLACK

Constructed from premium quality 100% pre-shrunk cotton and printed in vivid, fade-resistant colors, these quality made tee's have a classic Hurst Line-Loc logo in front and an illustration of the mighty Hurst Hemi Under Glass on the back.

74209G Small	\$18.99
74210G Medium	\$18.99
74211G Large	\$18.99
74212G X-Large	\$18.99
74213G 2X-Large	\$18.99
74214G 3X-Large	\$18.99

B. HURST NOSTALGIA II HAT

Made from a flexible fit material, this black hat is brimmed with a red accent with a prominent, classic Hurst Line-Loc logo embroidered on the front. Comes in two sizes that should stretch to fit.

74200G Hurst Nostalgic II Hat, S-M	\$22.00
74201G Hurst Nostalgic II Hat, Large	\$22.00

C. HURST NOSTALGIA T-SHIRT, WHITE

Constructed from premium quality 100% pre-shrunk cotton and printed in vivid, fade-resistant colors, these quality made tee's have a bold racing stripe with logo on the front and a large nostalgia Hurst logo on the back.

74109G Small	\$12.00
74110G Medium	\$12.00
74111G Large	\$12.00
74112G X-Large	\$12.00
74113G 2X-Large	\$15.00
74114G 3X-Large	\$15.00

D. INDIVIDUAL BRAND DECALS

Silk screened on vinyl, these self-adhesive decals stick to any clean, dry surface.

Hurst Logo, 5-1/2" x 6-1/4"	9300107
-----------------------------	----------------

A. Hurst Nostalgia II T-Shirt



B. Nostalgia II Hat



C. Nostalgia T-Shirt



PROMOTIONAL ITEMS

HURST PRODUCTS MAKE A STATEMENT ABOUT YOUR CAR, shouldn't it also make a statement about you? Hurst branded tee-shirts, hats, and iron-on patches are available for purchase. Make a fashion statement when you drive your Hurst equipped car!

D. Individual Brand Decals



A. Shifter Cables



A. SHIFTER CABLES

Replacement shifter cables are available for all Hurst automatic shifters. Additionally, several lengths of cables are available for the Quarter Stick and Pistol Grip shifters. These premium quality cables feature a solid 303 Stainless Steel inner wire core encased within a nylon liner wrapped with helical lay wires and swaged ends for superior strength. The core is lubricated with Teflon prior to assembly and then sealed in a heavy plastic outer casing for a lifetime of durability and smooth operation.

B. REPLACEMENT SHIFTER SPRINGS

Restore precise shifter action by replacing the weak or damaged springs in the Pro-Matic, V-Matic or Billet/Plus shifters. The Pro-Matic and V-Matic kit includes 1 of each centering, ratchet and position springs. **230 8500**

The Billet/Plus kit includes two of each inner and outer bias springs. **230 5000**

B. Shifter Springs



C. Hurst Pit Packs



C. HURST PIT PACKS

Available in either steel or nylon. Steel bushings are designed to take the punishment of racing applications and provide for longer service. Nylon bushings are designed for street applications and eliminate most of the stick vibrations. These pit packs can be used on the Master Shift 3-Speed, Competition Plus 4-Speed and the V-Gate 2. Kit includes either 7 steel or nylon bushings and spring clips.

SERVICE PARTS

STANDARD REPLACEMENT CABLES

CABLE LENGTH	PART NUMBER		
3 ft. Adjustable Single Eyelet	500 0023		
4 ft. Adjustable Single Eyelet	500 0024		
5 ft. Adjustable Single Eyelet	500 0025*		Auto Stick 3, Pistol Grip, Q-Stick/Q-Stick 2, Lightning Rods, Pick-up Truck Auto stick, Dual Gate 2, Van Auto Stick
8 ft. Adjustable Single Eyelet	500 0028		
5 ft. Adjustable Double Eyelet	500 0029**		Q-Stick (Late model Camaro, Monte Carlo)
5 ft. Adjustable Single Eyelet	500 8555***		Pro Matic 2, V-Matic 2

REPLACEMENT SHIFTER SPRINGS

APPLICATION	PART NUMBER
Pro-Matic and V-Matic, Billet/Plus	230 8500
	230 5000

HURST PIT PACKS

APPLICATION	DESCRIPTION	PART NUMBER
3, 4, and 5 speed manuals	Nylon bushings	332 0001
3, 4, and 5 speed manuals	Steel bushings	332 7302
V-Gate 2 only	Steel bushings	332 1657

IMPORTANT: Make sure the cable is not kinked, bent in too tight of a radius, touching the exhaust manifold or dragging. If this occurs, make the adjustment to eliminate the problem.

* Standard cable for most Quarter Stick shifters.

** Standard cable for Quarter Stick shifters No.s 316 0082, 316 0083

*** Standard cable for the Pro Matic 2 and V-Matic 2.

SERVICE PARTS

COMPETITION/PLUS, 4 SPEED INSTALLATION KITS

INSTALLATION KIT	MOUNTING PLATE	ARM 1 & 2	ARM 3 & 4	ARM REVERSE	ROD 1 & 2	ROD 3 & 4	ROD REVERSE
373 0017	195 0125	105 4293	105 4294	105 4295	213 0136	213 0137	213 0135
373 0021*	195 0199 ¹	105 0043	105 0044	105 2489	213 0163	213 0164	213 0165
373 0022*	195 0199 ¹	105 4293	105 4864	105 4295	213 0193	213 0194	213 0195
373 3157	195 7773	105 2140	105 2141	105 1670	213 2144	213 2145	213 2146
373 3162	195 8008	105 2440	105 2441	105 2445	213 2144	213 2145	213 2439
373 3163	195 7773	105 2440	105 2441	105 2442	213 2438	213 2139	213 3404
373 3164*	195 2482	105 2140	105 2488	105 2489	213 2486	213 2485	213 2487
373 3165*	195 2722	105 2723	105 2724	105 2725	213 2726	213 2727	213 2728
373 3166*	195 2816	105 2140	105 2141	105 1670	213 2814	213 2815	213 2444
373 3167*	195 2816	105 2723	105 2724	105 3698	213 3691	213 2774	213 3695
373 3668*	195 3176	105 3665	105 3666	105 3667	213 2758	213 3172	213 3137
373 4089	195 6348 ¹	105 3894	105 3831	105 2445	213 4164	213 3830	213 3189
			105 3667				
373 4297	195 4204	105 4293	105 4294	105 4295	213 4187	213 4188	213 4335
373 4354	195 4345	105 4346	105 2441	105 4347	213 4348	213 1588	213 2487
373 4529	117 5284 ³	105 5286	105 5287	105 2445	213 5307	213 2145	213 3691
373 4531	117 5284 ³	105 4293	105 4294	105 4295	213 5298	213 5299	213 5308
373 4648	195 8008	105 2440	105 2441	105 2445	213 2144	213 2145	213 2146
373 4734	195 7773	105 2140	105 2141	105 2142	213 2138	213 2139	213 3404
373 5587	117 6889	105 2723	105 2108	105 2725	213 1720	213 2774	213 3207
	195 6834						
373 6819*	195 0165 ¹	105 5286	105 2656	105 2442	213 2920	213 4769	213 6818
373 7131	117 5284 ³	105 7129	105 7130	105 7128	213 5307	213 2145	213 3691
373 7437	195 0164 ¹	105 7129	105 7130	105 7128	213 5307	213 2145	213 3691
373 7637	195 3176	105 2723	105 2108	105 7647	213 1720	213 2774	213 3207
373 7638	195 4120	105 2723	105 2108	105 7646	213 4146	213 2774	213 4147
373 7717*	195 7719 ¹	105 2723	105 2108	105 7647	213 1720	213 2774	213 3207
373 7823*	195 0165 ¹	105 7129	105 4294	105 7825	213 2920	213 4769	213 6818
373 7834	195 7773	105 7058	105 7060	105 7059	213 2438	213 2139	213 3404
373 7897	195 0163	105 7129	105 7130	105 7899	213 3646	213 2139	213 2137
373 7919	117 4208 ⁶	105 4293	105 4294	105 7923	213 4187	213 4188	213 4335
373 8604*	117 4208 ⁶	105 4293	105 4294	105 4295	213 4187	213 4188	213 4335
373 8605	195 0163 ¹	105 7129	105 7130	105 7899	213 3646	213 2139	213 2137
373 8607 ⁷	195 8008	105 4293	105 4294	105 0016	213 5298	213 5299	213 5307
373 8608*	195 0165 ¹	105 7129	105 4294	105 7825	213 2920	213 4769	213 6818
373 8609	195 0065 ¹	105 2440	105 2441	105 0028	213 4646	213 2139	213 6818
373 8611	195 8008	105 7058	105 7060	105 7061	213 0046	213 2145	213 2146
							213 4147
373 8613	195 2298	105 2141	105 0049	105 3667	213 2815	213 2145	213 0078
373 8615	195 8382	105 8383	105 2141	105 7647	213 8377	213 8378	213 8379
				105 0052			
373 8616	195 0037	105 2140	105 2141	105 0055	213 7803	213 0079	213 1699
		105 7058	105 7060	105 7075			213 7819
373 8617*	195 2298	105 4829	105 3894	105 3832	213 1588	213 8003	213 8037
373 8618	117 0084	105 4293	105 4294	105 0016	213 0037	213 0039	213 0038
	116 0010						
373 8620*	117 0158	105 3894	105 0070	105 0073	213 0152	213 1588	213 0153
373 8621*	195 0148	105 2440	105 2441	105 2445	213 0046	213 2145	213 0151

Installation kits marked with an asterisk (*) has been discontinued. Please call Hurst Sales and Services department for availability of service parts. 818.483.1366

1. Spacer plate	195 4319	6. U-Bolt	265 4388
3. U-Bolt	265 5293	7. Back-drive rod	213 0030
4. Bracket	117 6889	21. Stick Bolts and Stop Bolts	154 0071
5. Stick Spacer	228 8397		

QUARTER STICK, AUTOMATIC SHIFTER - CABLE OPERATED

PART NUMBER	TRANS MODEL	SHIFTER ONLY	CABLE BRACKET	TRANS ARM	CABLE	CONSOLE	INSTRUCTION
316 0001	Powerglide TH 200, 350, 375, 400	316 0003	117 0095 117 4778	105 0084 105 0080	500 0025	130 0041	159 0999
316 0006	TH 200, 350, 375, 400 C-6	316 0008	117 4778 117 0038	105 0080 105 0081	500 0025	130 0041	159 1004
316 0009	C-4 A727-904 A727-904	316 0011	117 0037 117 0094 117 0094	105 0081 105 0082 105 0082	500 0025	130 0041	159 1004
316 0014	C-4 C-6	316 0017	117 0037 117 0038	105 0081 105 0081	500 0025	130 0041	159 1018
316 0016	TH 250, 350, 375, 400	316 0018	117 4778 117 0199	105 0059	500 0025	130 0041	159 1009
316 0020	Powerglide TH 250, 350, 375, 400	316 0021	117 0098 117 0099	105 7000 105 0098	500 0025	130 0056	159 0998
316 0025	TH 250, 350, 375, 400 Powerglide	316 0026	117 0099 117 0098	105 0098 105 7000	500 0025	130 0056	159 0998
316 0030	TH 700 R4	316 0088	117 4778	105 0080	500 0025	140 0020	159 1032
316 0082	TH 700 R4	316 0019	117 4778	105 0080	500 0029		159 1010
316 0083	TH 700 R4	316 0087	117 4778		500 0029		159 1033



PRO-MATIC 2 & V-MATIC 2, AUTOMATIC SHIFTER - CABLE OPERATED

PART NUMBER	TRANS MODEL	CABLE BRACKET	TRANS ARM	CONSOLE BLACK	CONSOLE CHROME	BOOTPLATE CHROME	INDICATOR LENS COVER	NEUTRAL SAFETY BACK-UP SWITCH	RUBBER BOOT	SHIFTER CABLE	TRIGGER POLISHED
3838500	TH 250 & 350	117 8562	105 8561	129 8554	195 8551	--	241 8552 (Forward Body)	248 0021	114 8550	500 8555	--
	TH 400	117 8560	105 8561								
	C 6	117 8557	97093097								
	C 4	97093096	97093097								
	A 727 & 904	117 8563	105 8564								
383 8504	TH 700 R4	117 4778	105 8567	--	--	--	--	--	--	--	--
	TH 200 4R	117 4778	105 8572	--	--	--	--	--	--	--	--
383 8505	Powerglide	117 8565	105 8566	--	--	--	241 8553	--	--	--	--
383 8510	TH 250 & 350	117 8562	105 8561	--	--	--	241 8552	--	--	--	--
	TH 400	117 8560	105 8561								
	C 6	117 8557	97093097								
	C 4	97093096	97093097								
	A 727 & 904	117 8563	105 8564								
383 8511	TH 700 R4	117 4778	105 8567	--	--	--	169 0005	--	--	--	--
	TH 200 4R	117 4778	105 8572	--	--	--	--	--	--	--	--
383 8515	TH 250 & 350	117 8562	105 8561	--	--	195 8574	241 8570 (Forward Body)	--	114 8572	--	307 8576
	TH 400	117 8560	105 8561	--	--	--	--	--	--	--	--
383 8520	TH 250 & 350	117 8562	105 8561	--	--	--	241 8570	--	--	--	--
	TH 400	117 8560	105 8561								
	C 6	117 8557	97093097								
	A 727 & 904	117 8563	105 8564								
383 8521	TH 700 R4	117 4778	105 8567	--	--	--	--	--	--	--	--
	TH 200 4R	117 4778	105 8572	--	--	--	--	--	--	--	--
383 8525	Powerglide	117 8565	105 8566	--	--	--	--	--	--	--	--
383 8530	TH 250 & 350	117 8562	105 8561	--	--	--	241 8570	--	--	--	--
	TH 400	117 8560	105 8561	--	--	--	--	--	--	--	--
383 8531	TH 250 & 350	117 8562	105 8561	--	--	--	241 8570	--	--	--	--
	TH 400	117 8560	105 8561	--	--	--	--	--	--	--	--

REPLACEMENT SHIFTER SPRINGS (see pg. 31)

RESTORE PRECISE SHIFTER ACTION BY REPLACING THE WEAK OR DAMAGED SPRINGS IN THE PRO-MATIC, V-MATIC OR BILLET/PLUS SHIFTERS. The Pro-Matic and V-Matic kit includes 1 of each centering, ratchet and position springs, part #230 8500.

The Billet/Plus kit includes two of each inner and outer bias springs, part #230 5000.

MASTERSHIFT, 3-SPEED INSTALLATION KITS

INSTALL. KIT	MOUNTING BRACKET	STIFFENER BRACE	ARM L&R	ARM 2&3	ROD L&R	ROD 2&3	BAGGED HARDWARE	BAGGED HARDWARE	INST. SHEET	MISC
367 0006	117 0044 117 0045	116 0007	105 7135	105 7130	213 0024	213 0025	154 0053	154 0071 ²¹	159 0063	117 0006 ¹⁶
367 0012	117 0061	116 0017	105 0035	105 0036	213 4093	213 0058	154 0076	154 0071 ²¹	159 0100	114 8280 ¹⁰
	117 0062		105 0054	105 0056						
367 0013	117 0007	116 0004	105 4746	105 4747	213 4742	213 4741	154 0025	154 0071 ²¹	159 0101	114 8280 ¹⁰
		117 4777	--	--	213 0062	213 0063				117 0006 ¹⁶
367 0014	117 0071	116 0021	105 1573	105 2108	213 2001	213 0066	154 0095	--	159 0110	114 8280 ¹⁰
367 0023	117 0062	116 0016	105 0031	105 0032	213 0058	213 3601	154 0076	--	159 0156	--
	117 0061		105 0057	105 0058						
367 0025	117 0097	116 0025	105 4864	105 4865	213 0080	213 1588	154 0130	--	159 0166	114 8280 ¹⁰
	117 0096		--	--						
367 0027	117 0151	116 2319	105 7656	105 2320	213 2321	213 2322	154 0013	--	159 0927	114 8280 ¹⁰
					213 1562	213 0147				
367 3111	117 7154	116 7153	105 1526	105 1550	213 2007	213 2008	154 0016	154 0071 ²¹	159 0020	114 8280 ¹⁰
				105 1657						--
367 3112	117 8227	116 1734	105 1526	105 1550	213 1735	213 1736	154 0009	154 0071 ²¹	159 0003	114 8280 ¹⁰
					105 1657	--				--
367 7143	117 8228	--	105 7144	105 4864	213 4209	213 4210	154 0010	154 0071 ²¹	159 0014	114 8280 ¹⁰
			--	--						--
367 7640	--	195 3176	105 7645	105 1779	213 2758	213 3172	154 0024	154 0071 ²¹	159 0017	114 8280 ¹⁰
										--

- 6. U-Bolt 265 4388
- 10. Boot 114 8280
- 16. Back Up Light Switch Bracket 117 0006
- 21. Stick Bolts and Stop Bolts 154 0071

TRANSMISSION I.D. CHARTS

3-SPEED TRANSMISSION I.D. CHART

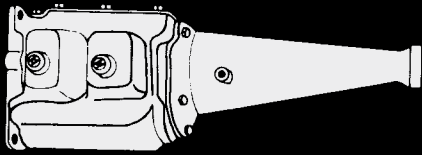

FORD (333)
9 bolt top cover; first gear synchronized

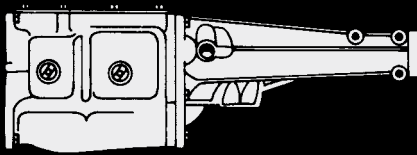

FORD (336)
9 bolt top cover; first gear synchronized

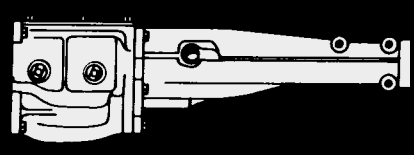

FORD (337)
4 or 6 bolt top cover; first gear not synchronized

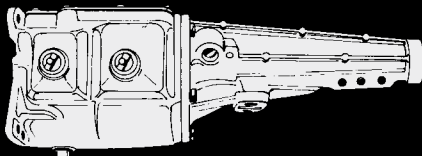

FORD (339)
9 bolt top cover; first gear synchronized

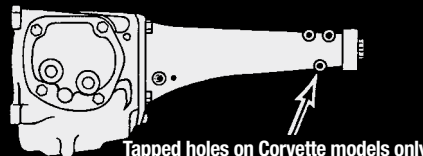

CHEVROLET (341)
4 bolt side cover with round gear selection shafts
Tapped holes on Corvette models only

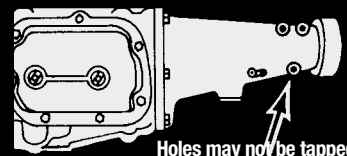

SAGINAW (343)
7 bolt side cover; first gear synchronized
CAUTION: This transmission closely resembles 351 Muncie
Holes may not be tapped

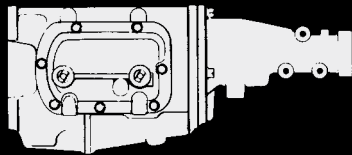

MUNCIE (351)
7 bolt side cover; first gear synchronized
CAUTION: This transmission closely resembles 343 Saginaw

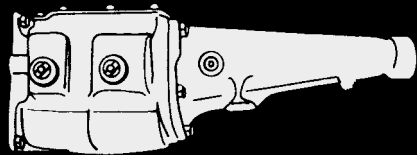

TREMEC (352)
9 bolt top cover; first gear synchronized

4-SPEED TRANSMISSION I.D. CHART

Early models have only these tapped holes

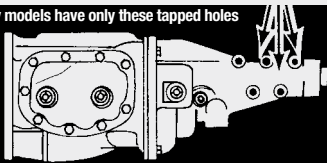

BORG-WARNER T-10, GM AS-3 (410)
9 bolt curved bottom side cover

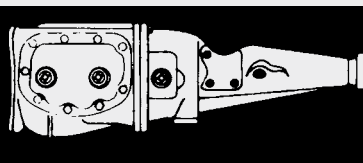

BORG-WARNER T-10, SUPER T-10, FORD/MERCURY (411)
9 bolt curved bottom side cover

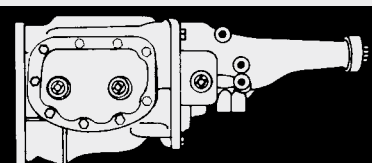

BORG-WARNER T-10, FORD/MERCURY (412)
9 bolt curved bottom side cover

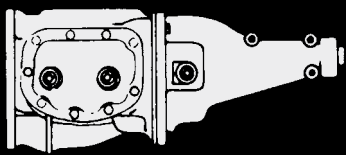

BORG-WARNER T-10 FORD/MERCURY (413)
9 bolt curved bottom side cover

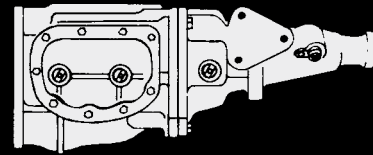

BORG-WARNER T-10, FORD/MERCURY (414)
9 bolt curved bottom side cover

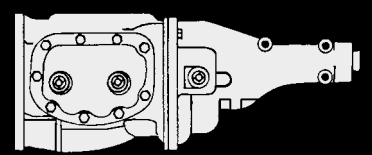

BORG-WARNER T-10 (415)
4 bolt side cover with round gear selection shafts

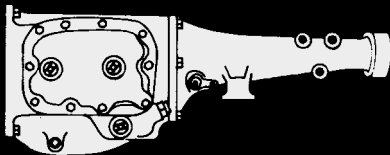

NEW PROCESS, MOPAR A-BODY (421)
10 bolt side cover

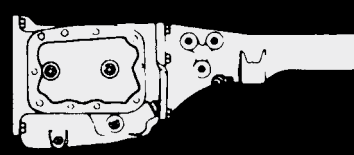

NEW PROCESS, MOPAR B-BODY (422)
10 bolt side cover

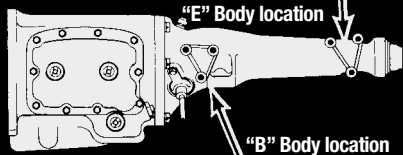

NEW PROCESS, MOPAR (423)
10 bolt side cover

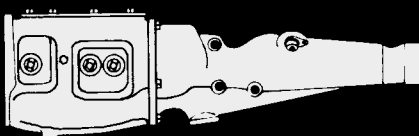

FORD T & C, FORD/MERCURY (431)
10 bolt top cover

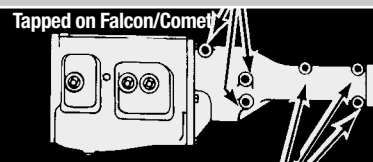

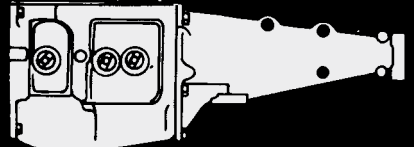

FORD 3+1 OVERDRIVE T & C, FORD/MERCURY (432)
10 bolt top cover
Tapped on Falcon/Comet



FORD T & C, FORD/MERCURY (433)
10 bolt top cover

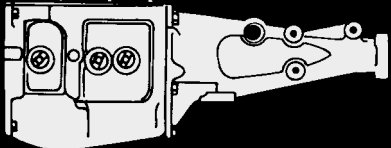
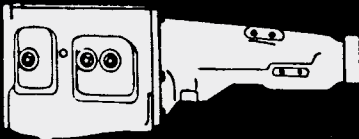
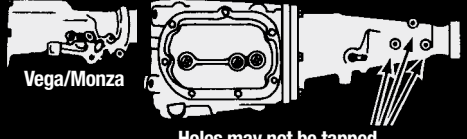
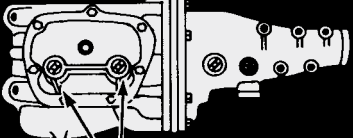
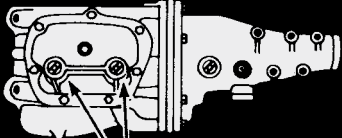
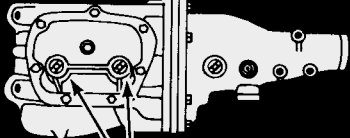
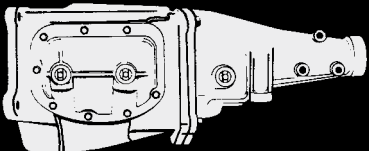
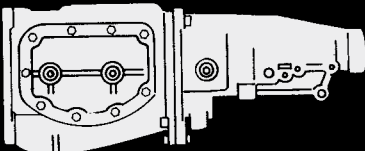
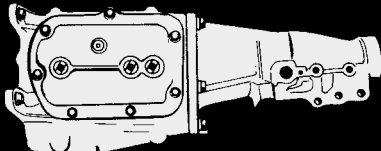

4-SPEED TRANSMISSION I.D. CHART (continued)

		 <p>Vega/Monza</p> <p>Holes may not be tapped</p>
<p>FORD T & C, FORD/MERCURY (434) 10 bolt top cover</p>	<p>FORD 3+1 OVERDRIVE FORD/MERCURY (435)</p>	<p>SAGINAW, G.M. (441) 7 bolt side cover</p>
 <p>Transmission arms attach with stud and nut*</p>	 <p>Transmission arms attach with bolt*</p>	 <p>Transmission arms attach with bolt</p>
<p>MUNCIE M-20/M-21 EARLY, G.M. (451) 7 bolt side cover used from 1963-68</p>	<p>MUNCIE M-20/M-21, G.M. (452) 7 bolt side cover 1969 and later</p>	<p>MUNCIE M-22 (453) G.M. 7 bolt side cover 1970, 454 Chevelle</p>
		
<p>RICHMOND/BORG-WARNER SUPER T-10, (AS-9) 1974 and later (454) 9 bolt curved bottom side cover</p>	<p>BORG-WARNER TORQUE TUBE TAILSHAFT, G.M. (455) 81-82 CAMARO/FIREBIRD 9 bolt side cover</p>	<p>SAGINAW TORQUE TUBE TAILSHAFT, G.M., 81-82 CAMARO/FIREBIRD (456) first gear synchronized</p>
<p>* MUNCIE Shaft Identification</p> <p>The above Muncie 4 speed transmissions can be distinguished from the style of the transmission arm attachment. Pre '69 Muncie's use a stud & nut at the indicated attachment point, while '69 and later Muncie's use a bolt as illustrated on the right.</p> <div style="display: flex; justify-content: space-around; align-items: center;"> <div data-bbox="976 982 1125 1117">  <p>PRE '69 MUNCIE & ALL BORG-WARNER SHAFTS TRANS I.D. 451</p> </div> <div data-bbox="1316 982 1444 1117">  <p>'69 & LATER MUNCIE TRANS I.D. 452, 453</p> </div> </div>		

5 AND 6-SPEED TRANSMISSION I.D. CHART

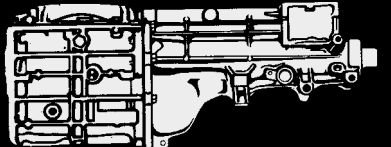
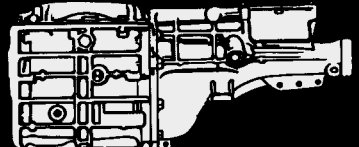
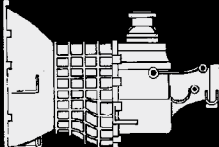
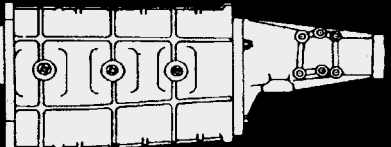
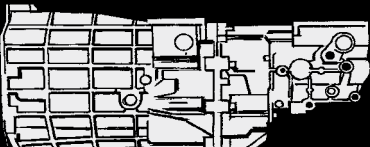
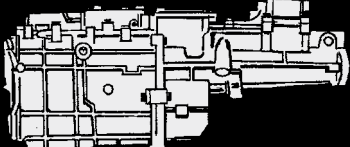
		
<p>BORG-WARNER T-5, GENERAL MOTORS (464) Internal Rail</p>	<p>BORG-WARNER T-5, FORD (465) Internal Rail</p>	<p>NEW VENTURE MG-5 (466) G.M. & Dodge Truck</p>
		
<p>RICHMOND GEAR DOUG NASH/ G-FORCE 5-SPEED (467)</p>	<p>BORG-WARNER T-56, G.M. (468)</p>	<p>TREMEC 3550 (469)</p>

CHROME-PLATED STEEL STICKS

HURST "BOLT-ON" SHIFTER STICKS ARE IDEAL FOR USE IN CUSTOM APPLICATIONS WHERE A PARTICULAR HEIGHT OR OFFSET IS REQUIRED. These shifter sticks are constructed from high strength steel and are stamped with the Hurst name. All sticks incorporate a 3/8-16 thread size for use with many popular Hurst T-handles and shifter knobs. Bolt hole size is 3/8" I.D. with 7/8" center-to-center spacing.

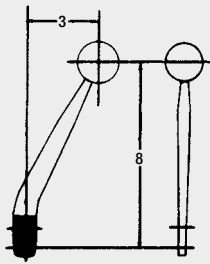

538 0015

Used on shifters
391 8790, 366 0005

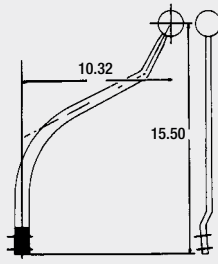

538 4078

Used on shifter 391 6789

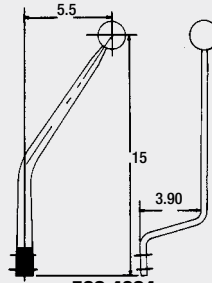

538 4084

Used on shifter 391 6790

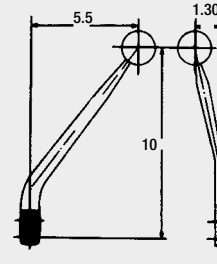

538 4106

Used on shifters 391 4339,
391 7879, 366 4550

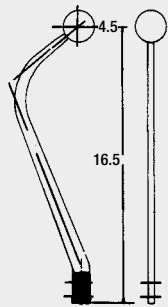

538 4331

Used on shifters 391 0001,
391 0002, 366 6809

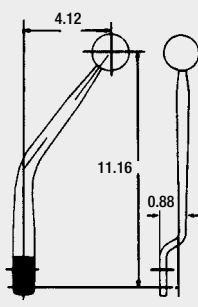

538 6836

Used on shifters 391 6822,
391 7072, 391 6848

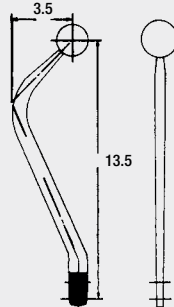

538 6900

Used on shifters
366 6901, 391 8403,
391 8404, 391 5045

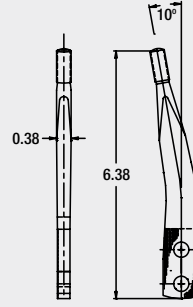

538 7201

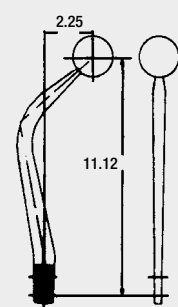

538 7236

Used on shifters
391 7308, 391 7307,
391 7930, 366 7271

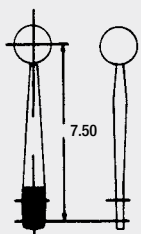

538 7238

Used on shifters 391 7535,
391 5061, 391 7960

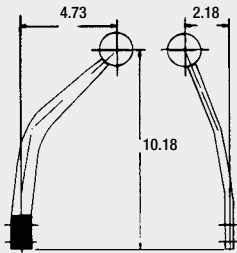

538 7436

Used on shifters
391 7438, 366 7954

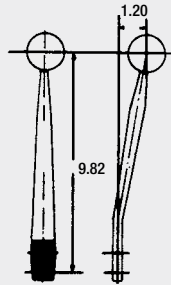

538 7991

Used on shifter
391 7992

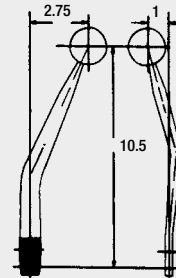

538 8009

Used on shifters 391 8014,
391 8791, 391 8794

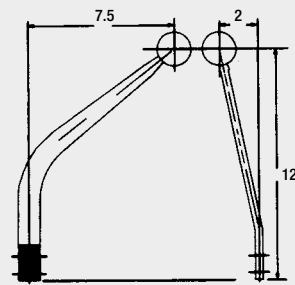

538 8022

Used on shifter 366 8034

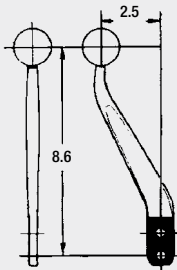

538 8550

Used on shifters
391 8790, 366 0005

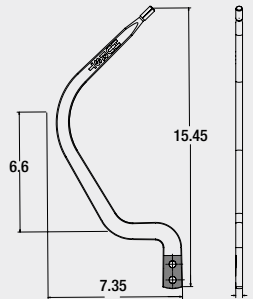

538 8620

Bench seat stick for
custom installation

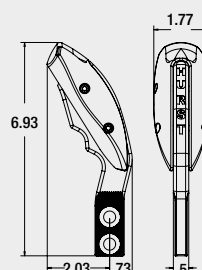

**538 8655 / 538 8665 /
538 8656**

See page 27 for application
and finishes

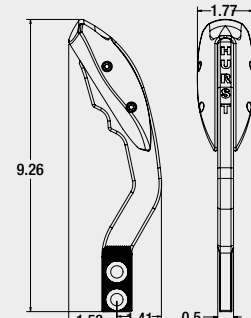

**538 8650 / 538 8660 /
538 8651**

See page 27 for application
and finishes



SHIFTER REBUILD SERVICE

HURST OFFERS A SPECIAL REBUILD SERVICE TO RESTORE YOUR HURST SHIFTER!

RESTORATION CHARGES	
MANUAL SHIFTERS	AUTOMATIC SHIFTERS
Competition Plus (all except OEM) Mastershifter 3-speed Street Super/Shifter 4-speed Super Shifter 3	Quarter Stick (all) Pro Matic 2 (all) V-Matic 2 (all) Street Rod Shifter
Billet Plus (all)	Auto/Stick 3 (Auto/Stick 1 & 2 cannot be serviced)
Richmond 5-speed Speedway Super Shifter	Dual/Gate 2 Dual/Gate OEM
Hurst OEM Shifters V-Gate 2 In-Line Shifter	
\$165.00	\$95.00
\$95.00	\$115.00
\$175.00	\$175.00
\$250.00	

Prices are subject to change without notice.

Please note on the form if the shifter is intended for racing applications. There will be a \$75 additional charge for re-chroming the stick. Standard shipping charge is \$10.50 for UPS Ground shipment to continental United States. Extra charge may apply for expedited shipping or shipping outside of the continental United States.

The charges above cover inspection and replacement of worn parts. Damaged, modified, missing or unusable components are extra. Excessively rusted or damaged shifters may not be rebuildable. Not responsible for parts that break during disassembly. Call for prices on any Hurst shifter not listed above.

SHIPPING CHARGES - \$10.50

(Via UPS ground service - Extra charges apply to shipments outside the continental U.S.A.)

For shifter rebuild service, fill out the form found on Hurst Shifter's website (www.hurst-shifters.com/hurst-shifter/shifter_rebuild.html), then fax the form to Hurst to request an RMA number. You will be notified of the RMA number. Be sure to write the RMA number on the address label, then send your shifter with a note describing any problems you may be encountering to:

**Hurst Performance
Shifter Rebuild Service**
9142 Independence Avenue
Chatsworth, CA 91311

Please allow a minimum of 6-8 weeks for shifter rebuild services. Actual time may vary based on demand. If you have any questions regarding shifter rebuilds, or for technical assistance with any Hurst product, contact the Hurst Technical Service Department at (818) 483-1366, 7:00am- 4:00pm PST, M-F, fax: (818) 882-6694.

HURST WARRANTY INFORMATION

This warranty covers the original purchasing consumer. This warranty is limited to repair or replacement by Hurst performance of any Hurst Performance Product that fails because of a defect in materials or workmanship. Implied warranty: Any warranties implied by law are limited to the duration of this warranty, (except in those states where prohibited by law).

HURST PERFORMANCE PRODUCTS WARRANTY COVERAGE

- 1 Year Limited Warranty – All Hurst brand shifters are covered for one year from the date of retail purchase to be free from defects in material and workmanship to the original purchaser (not warranted against normal wear, misuse or abuse).
- 90 Day Limited Warranty – All Indy brand shifters are covered for 90 days from the date of retail purchase to be free from defects in material and workmanship to the original purchaser (not warranted against normal wear, misuse or abuse).
- 90 Day Limited Warranty – Hurst Roll/Controls are covered for 90 days from the date of retail purchase to be free from defects in material and workmanship to the original purchaser (not warranted against normal wear, misuse or abuse).

WHAT IS NOT COVERED

- Failure of a Hurst Performance Product due to misapplication, improper installation or maintenance, misuse, abuse, unauthorized repairs, accidents, or modifications to the original design.
- Removal or replacement costs.
- Damage to related components.
- Costs incurred due to downtime of vehicle, towing cost or transportation costs.
- Normal wear and tear.
- Products used for racing – except shifters.
- Melted shifter cables.
- Shipping costs.

PRODUCT RETURN PROCEDURE

In the event a problem develops with a Hurst product, contact Hurst Performance Products: 818 483-1366 or Fax 818 882-6694. Ask for customer service. It may be determined the product will have to be returned to Hurst. A return material authorization number (RMA number) will be assigned to you. The retail store or customer should return the product in question, freight prepaid. It must be accompanied with the original purchase receipt and a clear description of the problem. If the product is determined to be defective and within the warranty period, Hurst will repair, replace or issue credit to the distributor at Hurst's option. Any repaired or replaced product will be returned to the sender freight prepaid via UPS. This limited warranty may give you specific legal rights, which may vary from state to state.

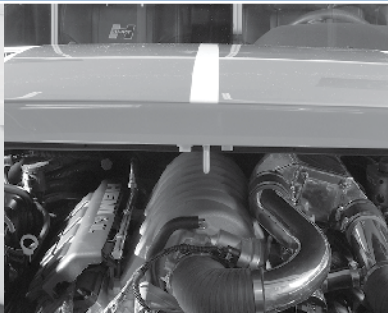
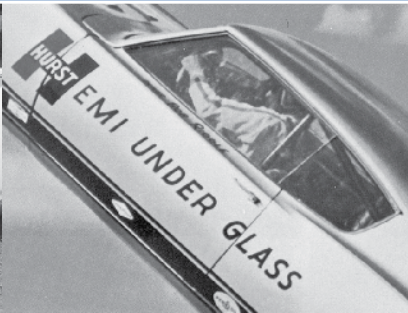

For the latest on Hurst Shifter products, please go to www.hurst-shifters.com



HURST PERFORMANCE PRODUCTS
9142 Independence Ave
Chatsworth, CA 91311
www.hurst-shifters.com

© 2011 Printed in U.S.A.

9100373-00